

8854

12502

20762

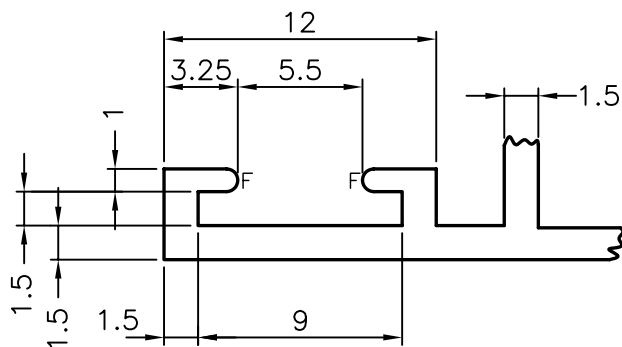

DETAIL 'A'

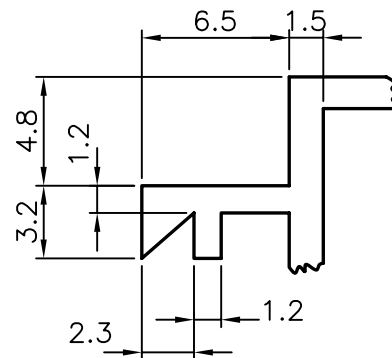

DETAIL 'B'

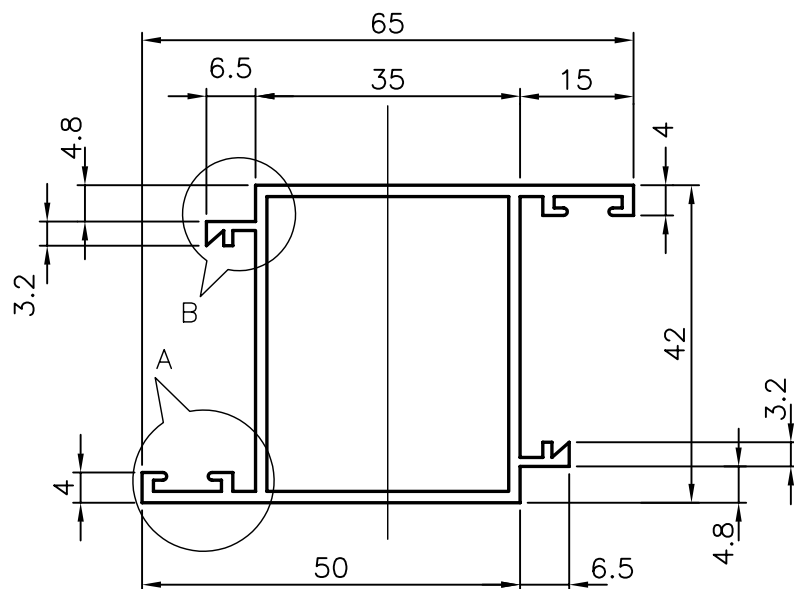

## NOTES:-

1. GENERAL WALL THICKNESS : 1.50 mm
2. F = FULL RADIUS (4)



SYMBOL OF QUALITY  
AN ISO 9002 COMPANY

**JINDAL ALUMINIUM LTD.**  
BANGALORE-560073 (INDIA)

	NAME	DATE
DRAWN	R.D.Sharma	21-06-94
CHECKED		
APPROVED		

1. ALL DIMENSIONS ARE IN mm.
2. ROUND OFF ALL SHARP CORNERS WITH 0.40 mm.
3. TOLERANCES WILL BE AS PER IS 6477-1983 UNLESS OTHERWISE SPECIFIED

PARTY'S NAME	UNIVERSAL ALUMINIUM CO., BAHRAIN	SCALE	1:1 & 3:1
PARTY'S DRAWING No.	4258	AREA mm <sup>2</sup>	313.57
ALLOY & TEMPER	HE9 WP	PERIMETER	176.6mm
DESCRIPTION	WINDOW SECTION	WEIGHT kg/m	0.848
		SECTION No.	20762
		DRAWING No.	20762