

8857

12505

20765

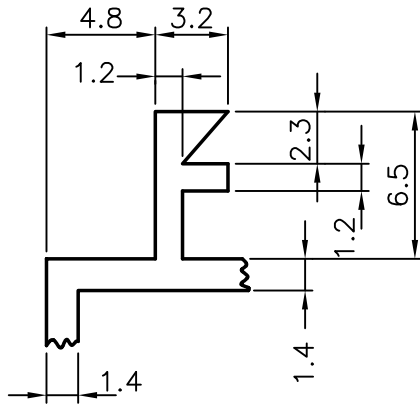

DETAIL 'A'

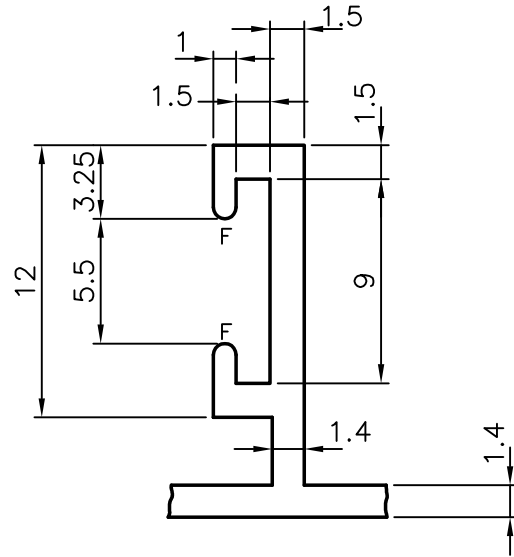

DETAIL 'B'

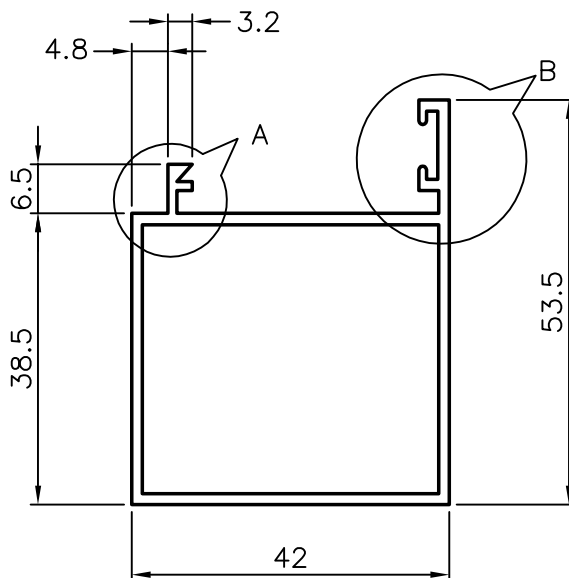

NOTES :-

1. GENERAL WALL THICKNESS : 1.40 mm
2. F = FULL RADIUS (2)



SYMBOL OF QUALITY
AN ISO 9002 COMPANY

JINDAL ALUMINIUM LTD.
BANGALORE-560073 (INDIA)

NAME

DATE

DRAWN

R.D.SHARMA 23.6.94

CHECKED

APPROVED

SCALE

1:1 & 3:1

PARTY'S NAME

UNIVERSAL ALUMINIUM CO.,
BAHRAIN

WEIGHT kg/m

0.710

PARTY'S DRAWING No.

H 5919

FINISH

SECTION No.

20765

ALLOY & TEMPER

HE 9WP

LENGTH:

5850mm.

DRAWING No.

DESCRIPTION

WINDOW SECTION

20765