

8865

20773

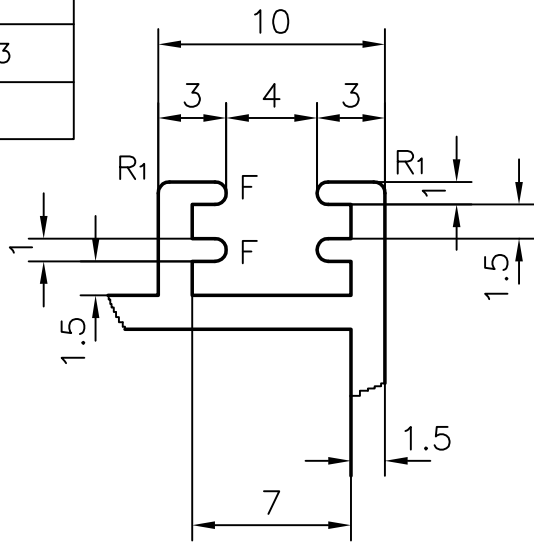
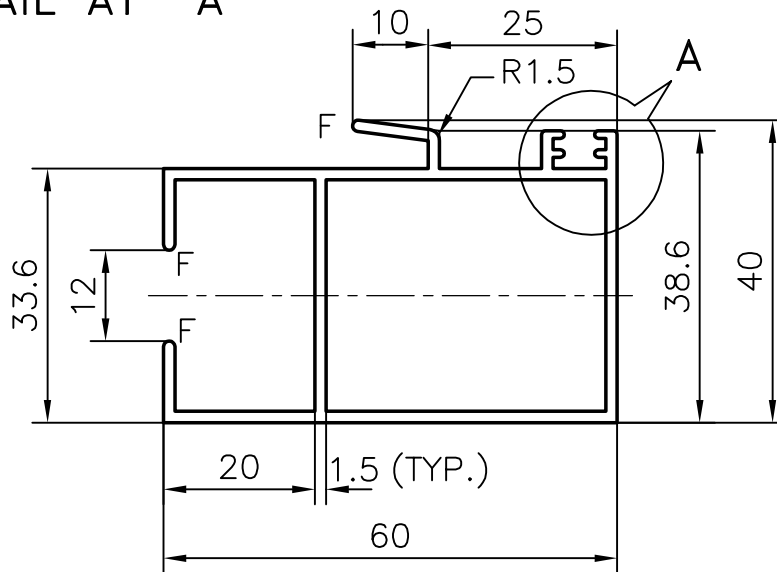

DETAIL AT "A"

GENERAL WALL THICKNESS: $-1.50^{+0.20}$

F= FULL RADIUS (7)

R= 0.50 RAD (2)

JINDAL ALUMINIUM LTD.**BANGALORE-560073**

NAME

DATE

DRAWN

R.D.Sharma

08-05-95

CHECKED

APPROVED

1. ALL DIMENSIONS ARE IN mm.
2. ROUND OFF ALL SHARP CORNERS WITH 0.4 mm.
3. TOLERANCES WILL BE AS PER IS : 6477-1983
UNLESS OTHERWISE SPECIFIED

PARTY'S NAME

APEX TRADING ESTABLISHMENT,DUBAI

SCALE

1:1 & 3:1

PARTY'S DRAWING No.

-

WEIGHT kg/m

0.923

ALLOY & TEMPER

HE9 WP

SECTION No.

20773

LENGTH

5850 mm.

DRAWING No.

DESCRIPTION

WINDOW SECTION

20773