

8871

12508

20779

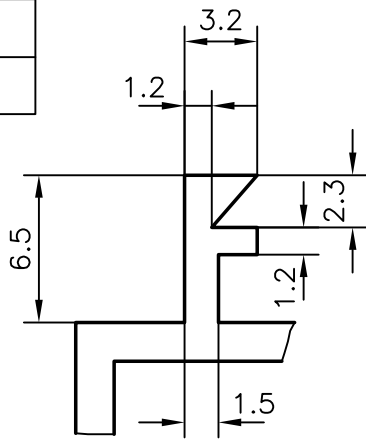

DETAIL AT "A"

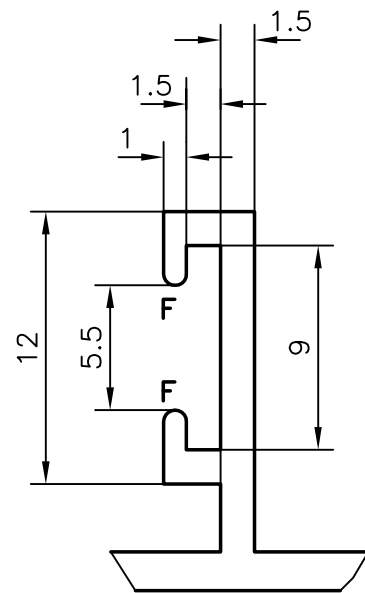

DETAIL AT "B"

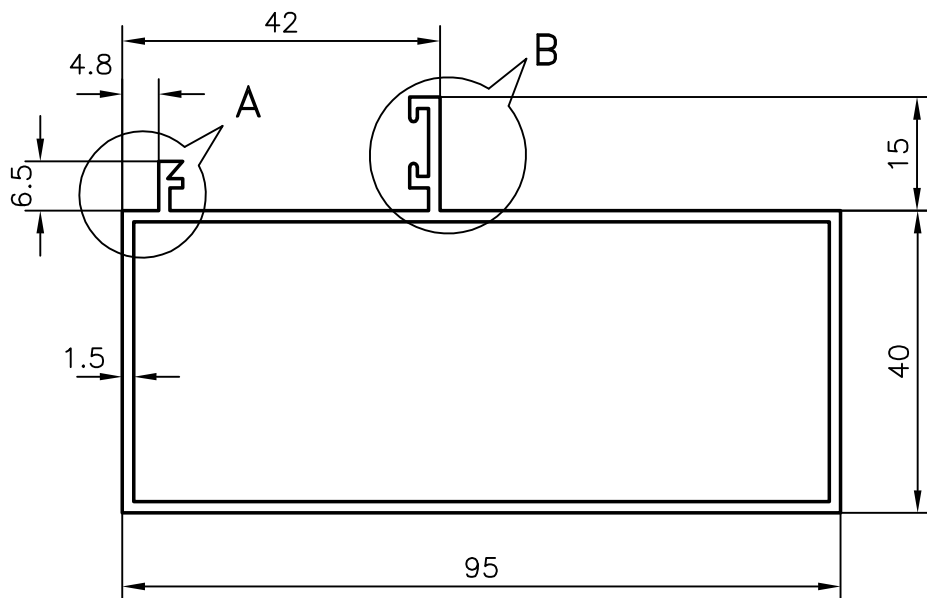

GENERAL WALL THICKNESS:-1.50 mm.  
F= FULL RADIUS (2)

**JINDAL ALUMINIUM LTD.**  
BANGALORE-560073

NAME

DATE

DRAWN

R.D.Sharma

16-8-95

CHECKED

APPROVED

1. ALL DIMENSIONS ARE IN mm.
2. ROUND OFF ALL SHARP CORNERS WITH 0.4 mm.
3. TOLERANCES WILL BE AS PER IS : 6477-1983  
UNLESS OTHERWISE SPECIFIED

PARTY'S NAME APEX TRADING ESTABLISHMENT,DUBAI

SCALE

1:1 &amp; 3:1

PARTY'S DRAWING No.

-

WEIGHT kg/m

1.195

ALLOY &amp; TEMPER

HE9 WP (6063 T6)

SECTION No.

20779

LENGTH

5850 mm.

DRAWING No.

DESCRIPTION

WINDOW SECTION

20779