

8872

20780

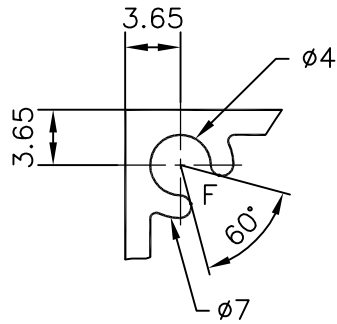

DETAIL AT "A"

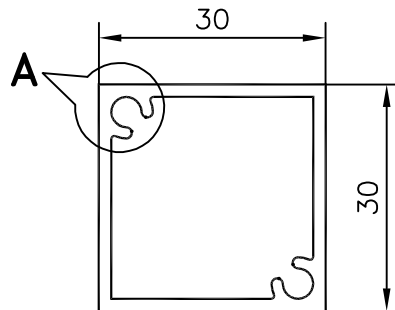

GENERAL WALL THICKNESS:-1.65 mm.

F= FULL RADIUS (4)

JINDAL ALUMINIUM LTD.
BANGALORE-560073

1. ALL DIMENSIONS ARE IN mm.
2. ROUND OFF ALL SHARP CORNERS WITH 0.4 mm.
3. TOLERANCES WILL BE AS PER IS : 6477-1983
UNLESS OTHERWISE SPECIFIED

		NAME	DATE
		DRAWN	R.D.Sharma
		CHECKED	
		APPROVED	
PARTY'S NAME	APEX TRADING ESTABLISHMENT,DUBAI	SCALE	1:1 & 2:1
PARTY'S DRAWING No.	-	WEIGHT kg/m	0.557
ALLOY & TEMPER	HE9 WP (6063 T6)	SECTION No.	20780
LENGTH	5850 mm.	DRAWING No.	20780
DESCRIPTION	WINDOW SECTION		