

8875

12509

20782

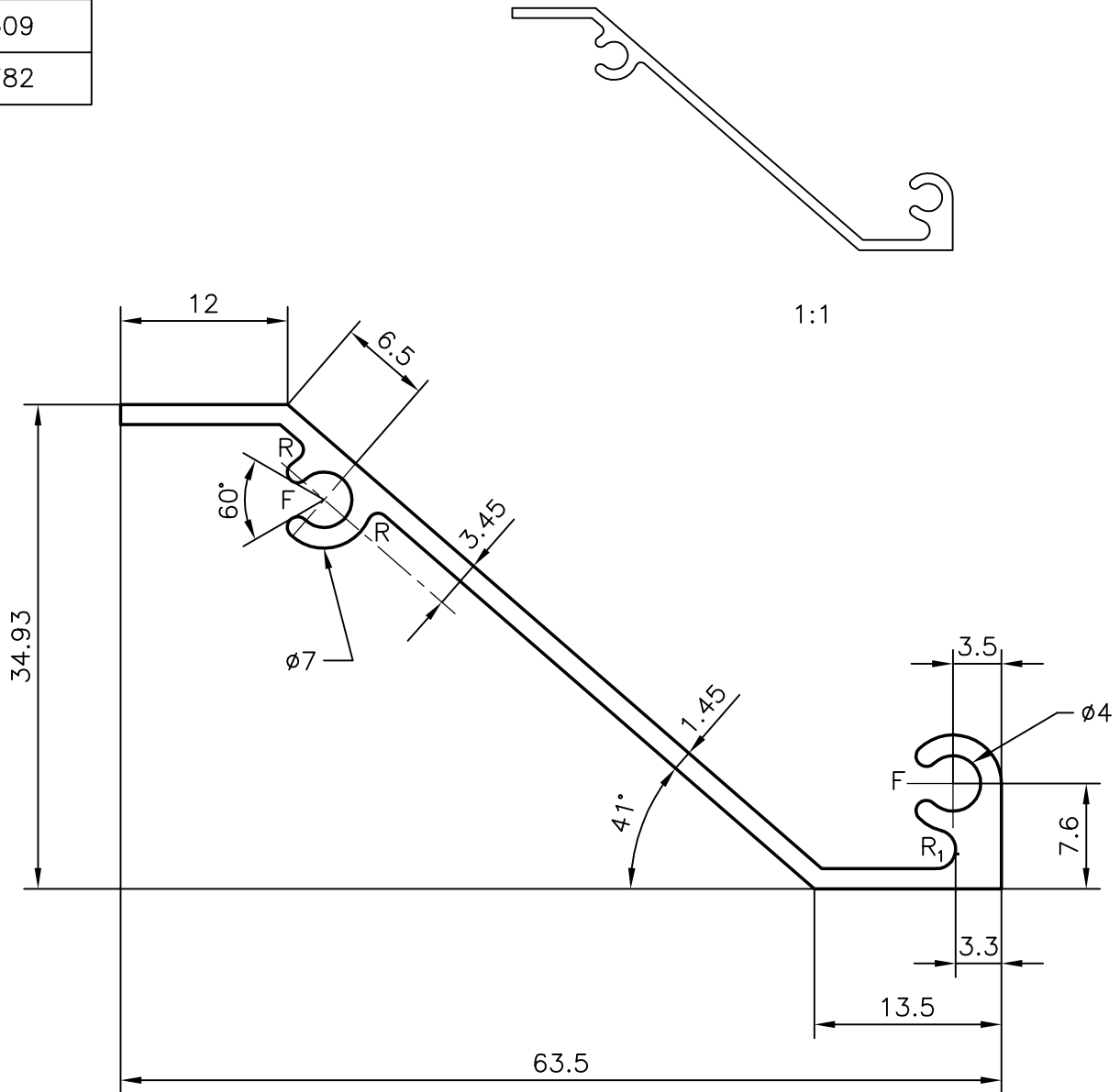

GENERAL WALL THICKNESS:-1.45 mm.

F = FULL RADIUS (4)

R = 0.75 RAD(2)

R₁ = 1.40 RAD(1)

JINDAL ALUMINIUM LTD.
BANGALORE-560073

NAME

DATE

DRAWN

R.D.Sharma

30-8-95

CHECKED

APPROVED

1. ALL DIMENSIONS ARE IN mm.
2. ROUND OFF ALL SHARP CORNERS WITH 0.4 mm.
3. TOLERANCES WILL BE AS PER IS : 3965-1981 UNLESS OTHERWISE SPECIFIED

PARTY'S NAME

APEX TRADING ESTABLISHMENT,DUBAI

SCALE

2:1

PARTY'S DRAWING No.

-

WEIGHT kg/m

0.429

ALLOY & TEMPER

HE9 WP (6063 T6)

SECTION No.

20782

LENGTH

5850 mm.

DRAWING No.

20782

DESCRIPTION

WINDOW SECTION