

8877

20783

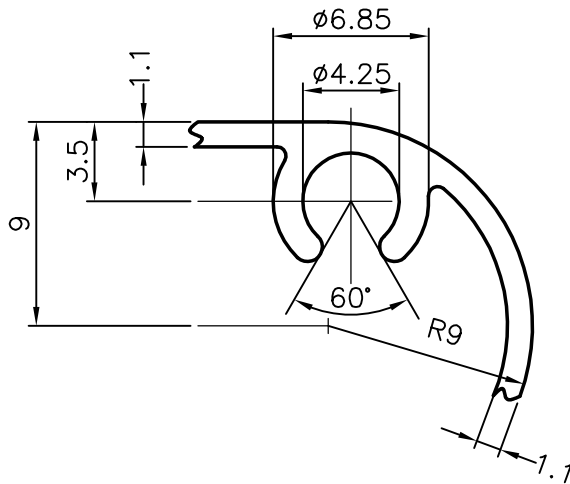

DETAIL AT 'A' (TYP.)

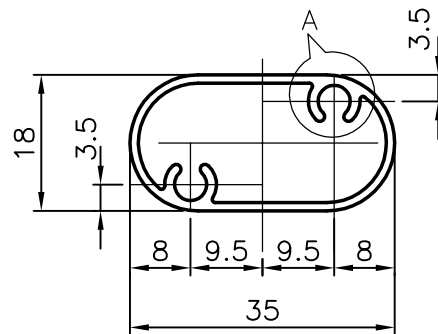

NOTE:—

1. AVERAGE WEIGHT OF 12' LONG PIECE : 1.235 kgs.

 SYMBOL OF QUALITY AN ISO 9002 COMPANY	JINDAL ALUMINIUM LTD. BANGALORE-560073 (INDIA)				NAME	DATE
				DRAWN	R.D.SHARMA	4.8.93
1. All dimensions are in mm. 2. Round off all sharp corners with 0.4mm R. 3. Tolerances will be as per IS: 6477-1983.				CHECKED		
				APPROVED		
				SCALE	1:1 & 3:1	
PARTY'S NAME	SUPER ALUMINIUM COMPANY. COCHIN			WEIGHT kg/m	0.337	
PARTY'S DRAWING No.		FINISH		SECTION No.	20783	
ALLOY & TEMPER	HE 9WP	3650T14		DRAWING No.		
DESCRIPTION	WINDOW SECTION			20783		