

8883

20788

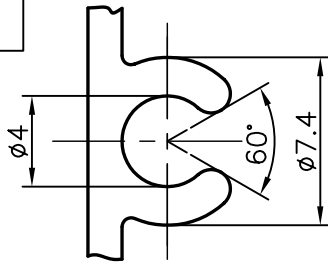

DETAIL AT 'A' (TYP)

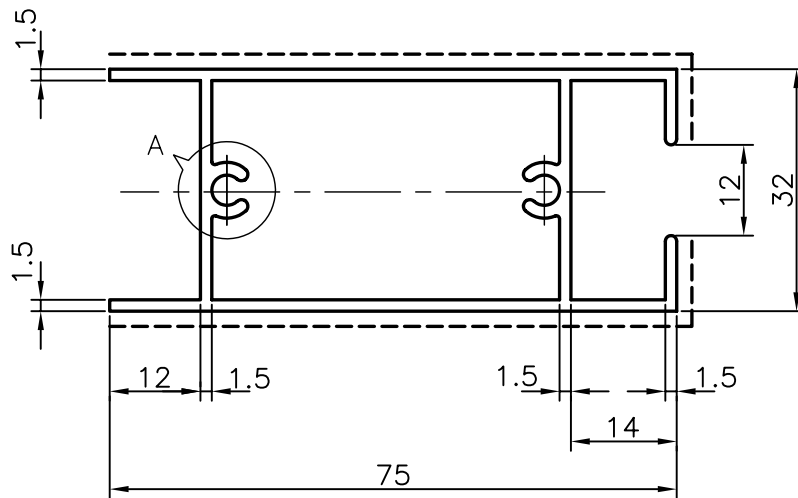

## NOTE:—

1. GENERAL WALL THICKNESS:—1.5mm
2. F—FULL RADIUS
3. -----EXPOSED SURFACE

 SYMBOL OF QUALITY AN ISO 9002 COMPANY	<b>JINDAL ALUMINIUM LTD.</b> <b>BANGALORE-560073 (INDIA)</b>			NAME	DATE
				DRAWN	R.D.SHARMA
1. ALL DIMENSIONS ARE IN mm. 2. ROUND OFF ALL SHARP CORNERS WITH 0.4mm R. 3. TOLERANCES WILL BE AS PER IS:3965- 1981.				CHECKED	
				APPROVED	
				SCALE	1:1 & 3:1
PARTY'S NAME	APEX TRADING ESTABLISHMENT DUBAI			WEIGHT kg/m	1.005
PARTY'S DRAWING No.	PD 914-43	FINISH	AS EXTRUDED	SECTION No.	<del>8883</del> 20788
ALLOY & TEMPER	HE9 WP	LENGTH:	5850mm	DRAWING No.	<del>8883</del> 20788
DESCRIPTION	WINDOW SECTION				