

8889
12512
20794

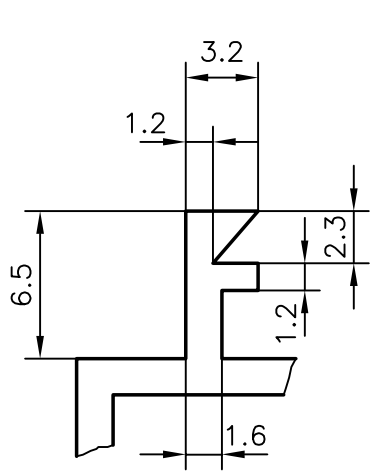

DETAIL AT "A"

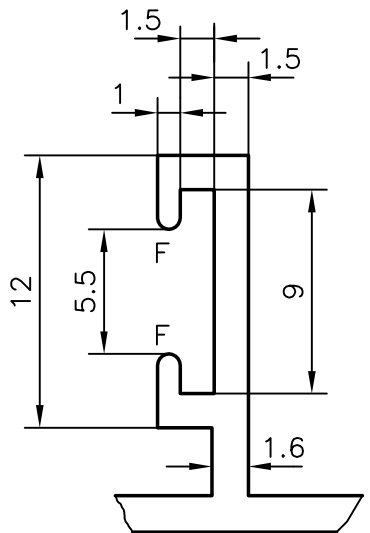

DETAIL AT "B"

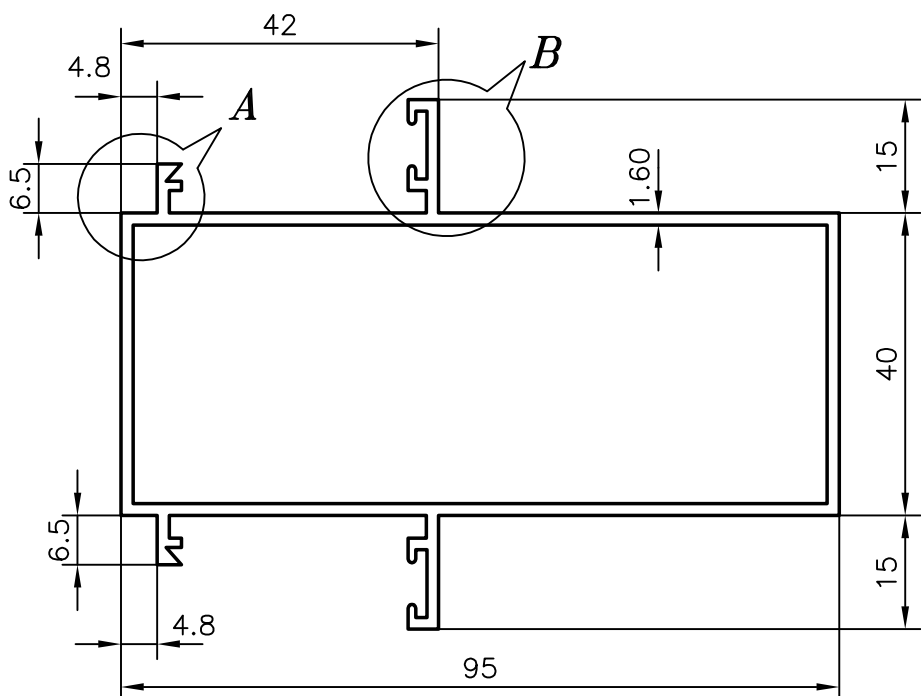

GENERAL WALL THICKNESS:-1.60 mm.
F =FULL RADIUS (4)

JINDAL ALUMINIUM LTD.
BANGALORE-560073

- 1. ALL DIMENSIONS ARE IN mm.
- 2. ROUND OFF ALL SHARP CORNERS WITH 0.4 mm.
- 3. TOLERANCES WILL BE AS PER IS: 6477-1983 ,UNLESS OTHERWISE SPECIFIED

PARTY'S NAME APEX TRADING ESTABLISHMENT,DUBAI		NAME		DATE	
		DRAWN		R.D.Sharma 14-02-96	
PARTY'S DRAWING No. -		CHECKED			
		APPROVED			
ALLOY & TEMPER HE9 WP		SCALE		1:1 & 3:1	
LENGTH 5850 mm.		WEIGHT kg/m		1.394	
DESCRIPTION WINDOW SECTION		SECTION No.		20794	
		DRAWING No.		20794	