

8896  
12341  
20800

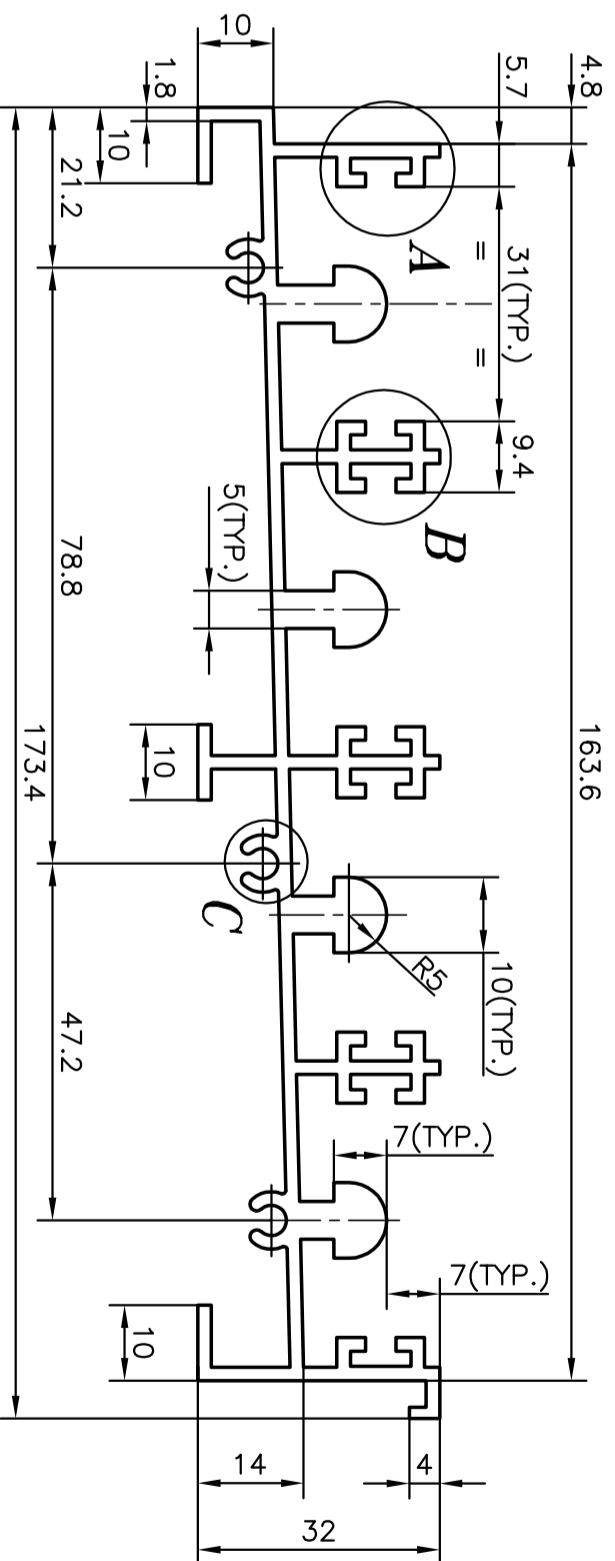
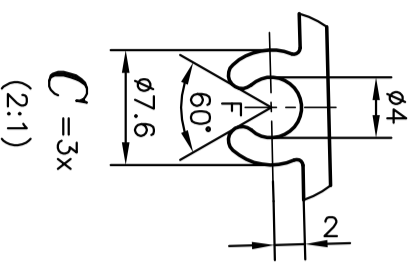
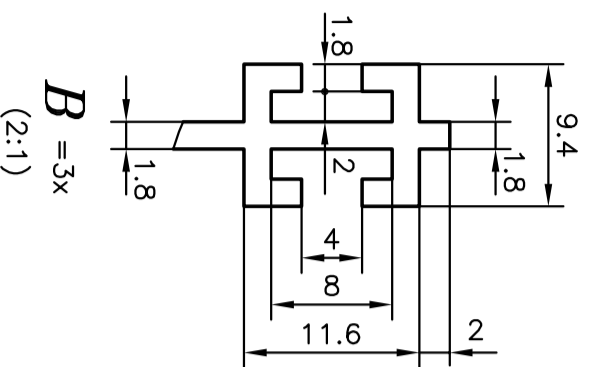
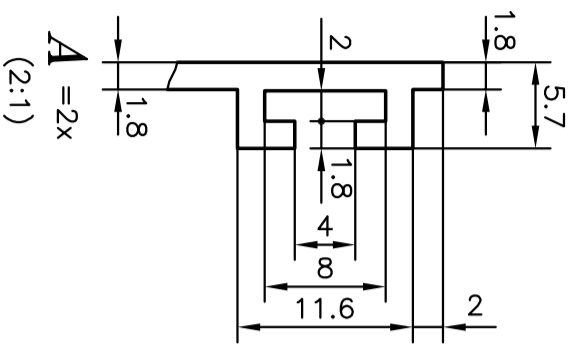

1. GENERAL WALL THICKNESS:- 1.80 mm.,  
UNLESS OTHERWISE SPECIFIED
2. F =FULL RADIUS(6)

<p align="center"><b>JINDAL ALUMINIUM LTD.</b> BANGALORE-560073</p>		DRAWN	R.D.Sharma	DATE	20-07-96
		CHECKED			
<p>1. ALL DIMENSIONS ARE IN mm. 2. ROUND OFF ALL SHARP CORNERS WITH 0.4 mm. 3. TOLERANCES WILL BE AS PER IS: 3965-1981 ,UNLESS OTHERWISE SPECIFIED</p>		APPROVED			
PARTY'S NAME	AGARWAL ALLOY AGENCY, MUMBAI	SCALE	1:1 & 2:1		
PARTY'S DRAWING No.	AS PER SKETCH	WEIGHT kg/m	3.160		
ALLOY & TEMPER	HE9 WP	SECTION No.	20800		
LENGTH	3658 mm.	DRAWING No.	20800		
DESCRIPTION	WINDOW SECTION				