

8902
12014
20806

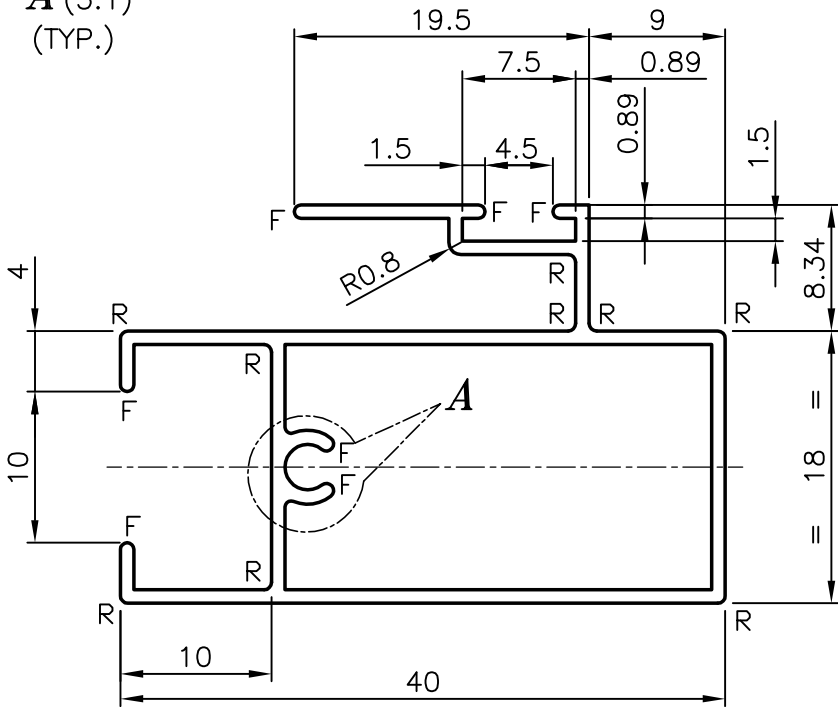
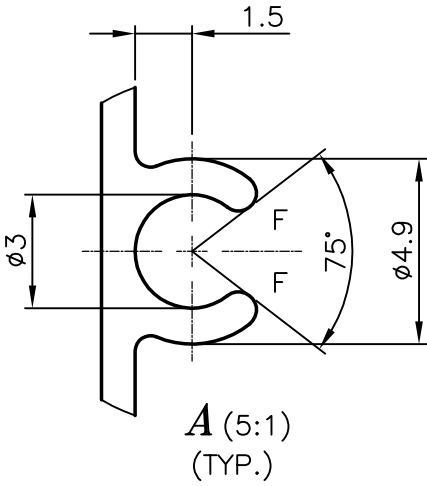
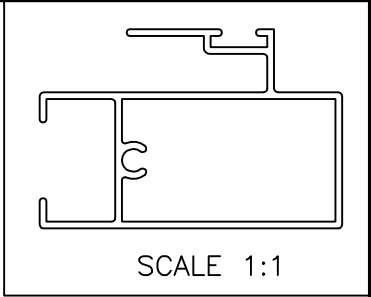

1. GENERAL WALL THICKNESS :- 0.89 mm.
2. 3658 mm. LONG PIECES IN 100 kgs. :- 72 (AVERAGE)
3. F = FULL RADIUS (7 PLACES)
4. R = 0.50 RADIUS (9 PLACES)

JINDAL ALUMINIUM LTD.
BANGALORE-560073

	NAME	DATE
DRAWN	R.D.Sharma	16-07-97

1. ALL DIMENSIONS ARE IN mm.
2. ROUND OFF ALL SHARP CORNERS WITH 0.4 mm.
3. TOLERANCES WILL BE AS PER IS: 6477-1983 ,UNLESS OTHERWISE SPECIFIED

CHECKED		
APPROVED		

PARTY'S NAME	GENERAL CATEGORY	SCALE	1:1,2:1&5:1
PARTY'S DRAWING No.	-	WEIGHT kg/m	0.380
ALLOY & TEMPER	HE9 WP	SECTION No.	20806
LENGTH	3658 mm.	DRAWING No.	
DESCRIPTION	WINDOW SECTION	20806	