

8904

11926

20808

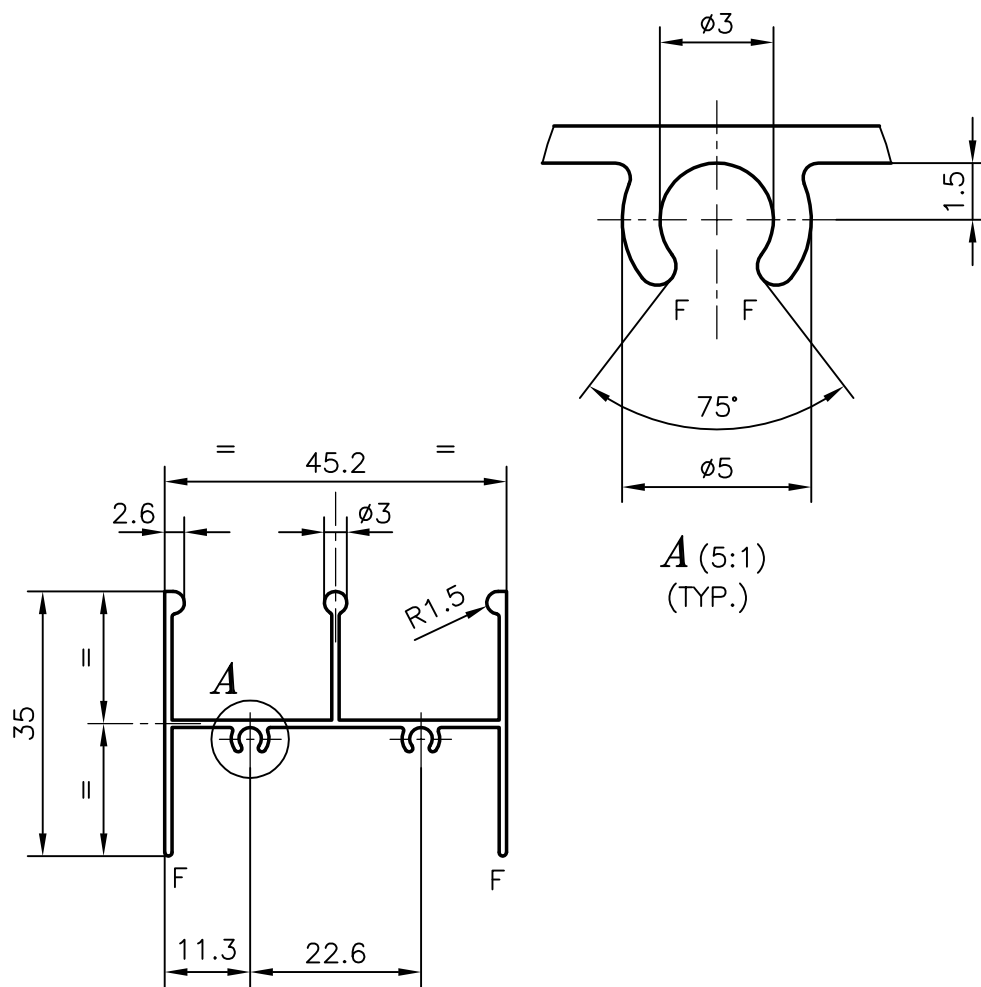

1. GENERAL WALL THICKNESS :- 0.98 mm.
2. F = FULL RADIUS (6)
3. 3658 mm. LONG PIECES IN 100 kgs. :- 66 (AVERAGE)

JINDAL ALUMINIUM LTD.

BANGALORE-560073

1. ALL DIMENSIONS ARE IN mm.
2. ROUND OFF ALL SHARP CORNERS WITH 0.4 mm.
3. TOLERANCES WILL BE AS PER IS: 3965-1981 ,UNLESS OTHERWISE SPECIFIED

JINDAL ALUMINIUM LTD. BANGALORE-560073		NAME	DATE
PARTY'S NAME	GENERAL CATEGORY	DRAWN	R.D.Sharma 24-07-97
PARTY'S DRAWING No.	NIL	CHECKED	
ALLOY & TEMPER	HE9 WP	APPROVED	
LENGTH	3658 mm.	SCALE	1:1 & 5:1
DESCRIPTION	WINDOW SECTION	WEIGHT kg/m	0.414
		SECTION No.	20808
		DRAWING No.	20808