

8908
12024
20812

DETAIL OF "A"
SCALE 3:1

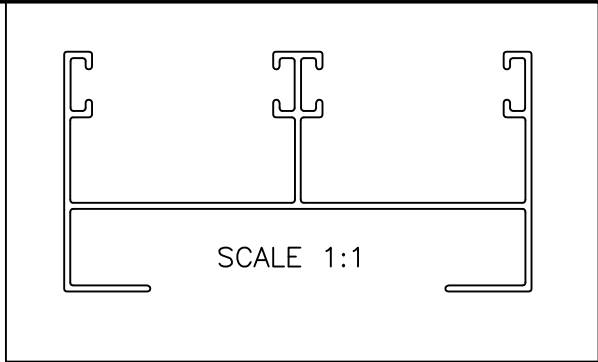

DETAIL OF "B"
SCALE 3:1

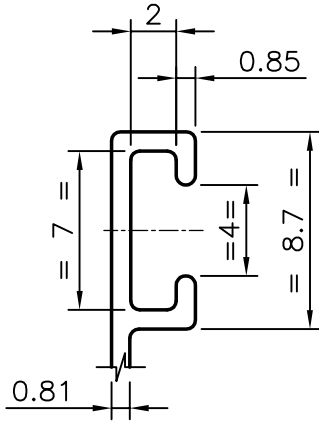
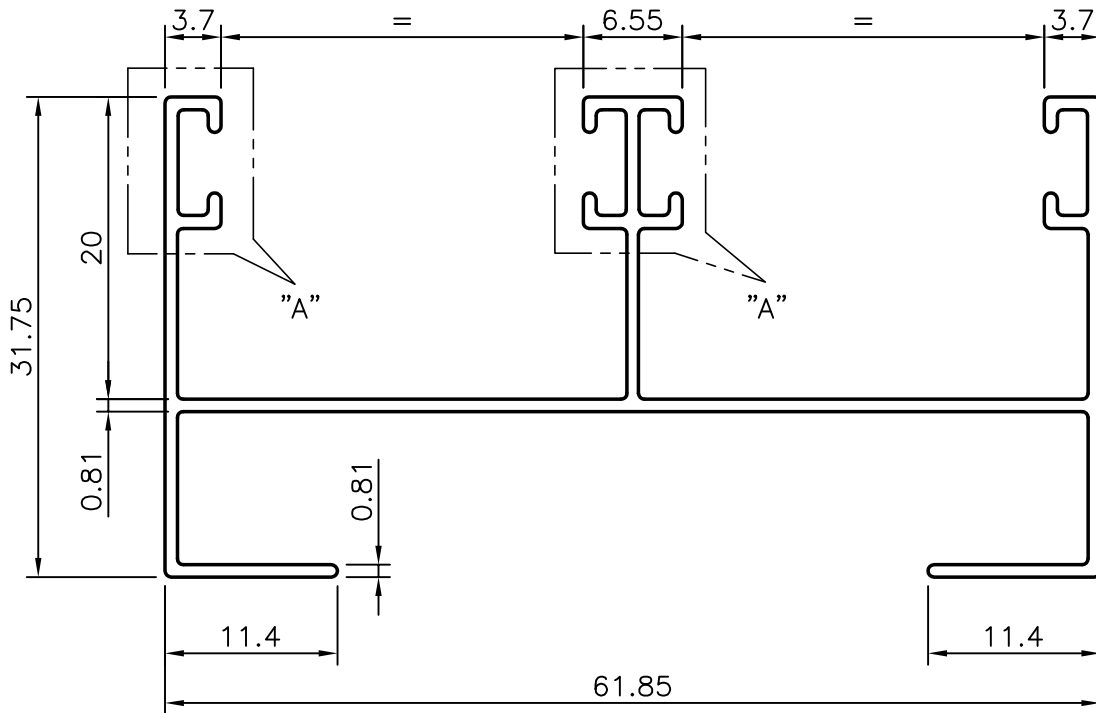
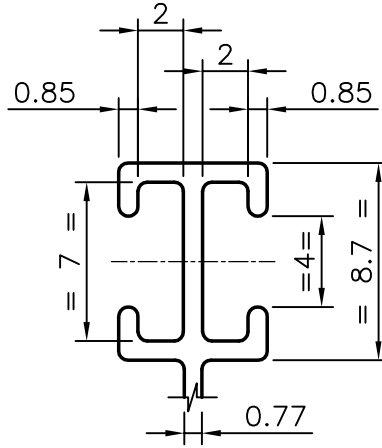

3658 mm. LONG PIECES IN 100 kgs:- 62 (AVERAGE)

 SYMBOL OF QUALITY AN ISO 9001 COMPANY	JINDAL ALUMINIUM LTD. BANGALORE-560073 (INDIA)	NAME	DATE
		DRAWN	PRASANN.H 18-10-2007
1. ALL DIMENSIONS ARE IN mm. 2. ROUND OFF ALL SHARP CORNERS WITH 0.40 mm. 3. TOLERANCES WILL BE AS PER IS:3965-1981 UNLESS OTHERWISE SPECIFIED		CHECKED	
		APPROVED	
PARTY'S NAME -		SCALE	2:1
		AREA mm ²	163.537
PARTY'S DRAWING No. -		PERIMETER mm.	390.879
		WEIGHT kg/m	0.441
ALLOY & TEMPER HE9 WP		DRAWING No.	SECTION No.
		8908	8908
DESCRIPTION WINDOW SECTION		12024	12024
		20812	20812