

8930

12517

20828

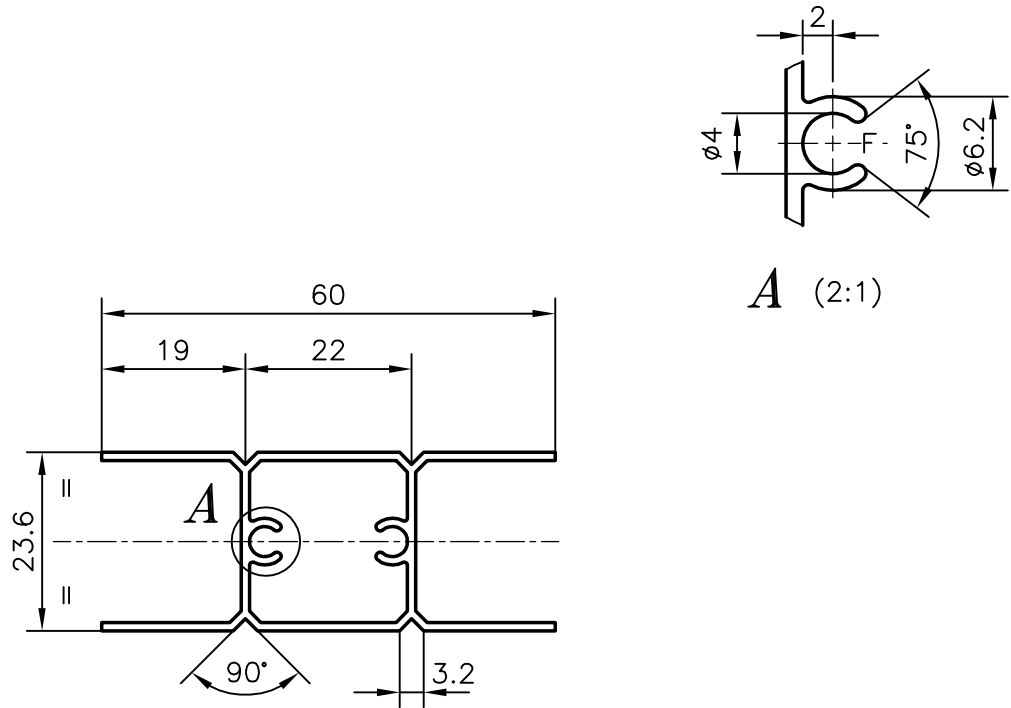

A (2:1)

1. GENERAL WALL THICKNESS :- 1.10 mm.
2. F = FULL RADIUS (4)
3. WEIGHT PER PIECE :- 1.900 kgs TO 2.000 kgs

JINDAL ALUMINIUM LTD.

BANGALORE-560073

JINDAL ALUMINIUM LTD. BANGALORE-560073		NAME	DATE
		DRAWN	R.D.Sharma
1. ALL DIMENSIONS ARE IN mm. 2. ROUND OFF ALL SHARP CORNERS WITH 0.4 mm. 3. TOLERANCES WILL BE AS PER IS: 6477-1983 ,UNLESS OTHERWISE SPECIFIED		CHECKED	
		APPROVED	
PARTY'S NAME	MUMBAI MARKET	SCALE	1:1 & 2:1
PARTY'S DRAWING No.	-	WEIGHT kg/m	0.535
ALLOY & TEMPER	HE9 WP	SECTION No.	20828
LENGTH	3658 mm.	DRAWING No.	
DESCRIPTION	WINDOW SECTION	20828	