

8945

12261

20842

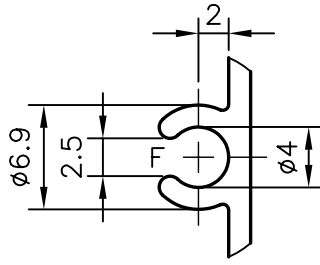

A (2:1)

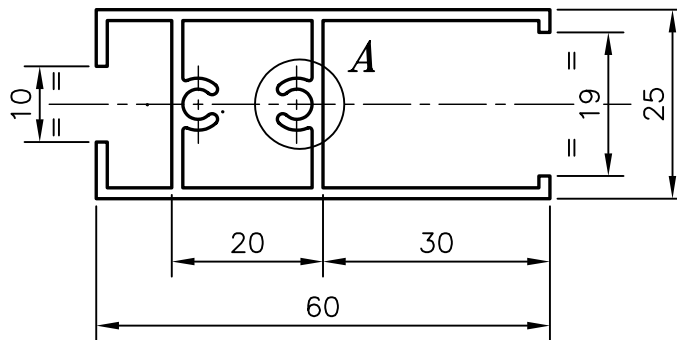

1. GENERAL WALL THICKNESS :- 1.45 mm.
2. F = FULL RADIUS (4)
3. NO. OF PIECES IN 100 kgs. :- 35 (AVERAGE)

JINDAL ALUMINIUM LTD.

BANGALORE-560073

NAME

DATE

DRAWN

R.D.Sharma

28-01-98

CHECKED

APPROVED

1. ALL DIMENSIONS ARE IN mm.
 2. ROUND OFF ALL SHARP CORNERS WITH 0.4 mm.
 3. TOLERANCES WILL BE AS PER IS: 6477-1983 ,UNLESS OTHERWISE SPECIFIED

PARTY'S NAME

MUMBAI MARKET

SCALE

1:1 & 2:1

PARTY'S DRAWING No.

NIL

WEIGHT kg/m

0.781

ALLOY & TEMPER

HE9 WP

SECTION No.

20842

LENGTH

3658 mm.

DRAWING No.

DESCRIPTION

WINDOW SECTION

20842