

8960

12332

20857

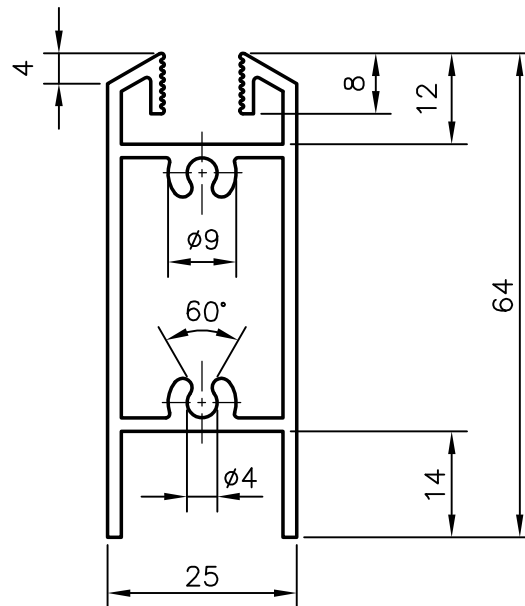
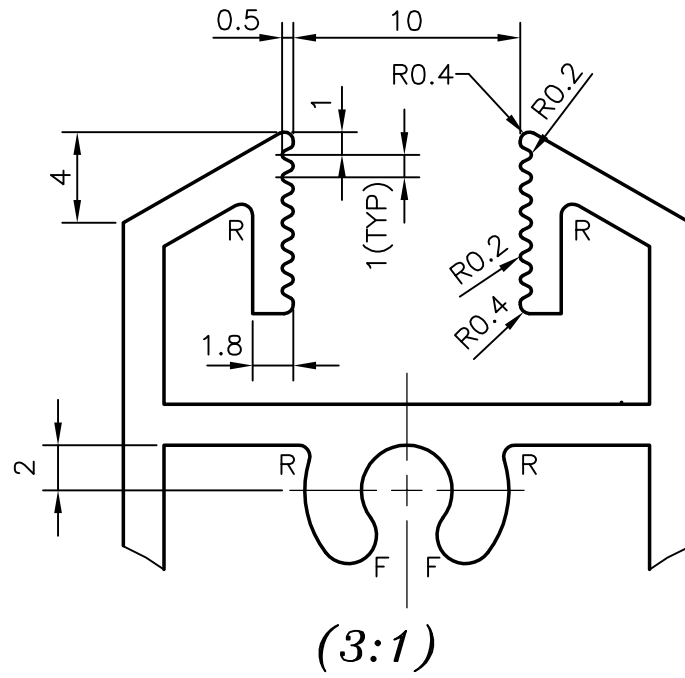

1. GENERAL WALL THICKNESS:- 1.80 mm.,
UNLESS OTHERWISE SPECIFIED
2. F = FULL RADIUS (4)
3. R = 0.50 RADIUS (6)

JINDAL ALUMINIUM LTD.

BANGALORE-560073

1. ALL DIMENSIONS ARE IN mm.
2. ROUND OFF ALL SHARP CORNERS WITH 0.4 mm.
3. TOLERANCES WILL BE AS PER IS: 6477-1983 ,UNLESS OTHERWISE SPECIFIED

JINDAL ALUMINIUM LTD.		NAME	DATE
BANGALORE-560073		DRAWN R.D.Sharma	01-06-98
1. ALL DIMENSIONS ARE IN mm.		CHECKED	
2. ROUND OFF ALL SHARP CORNERS WITH 0.4 mm.		APPROVED	
3. TOLERANCES WILL BE AS PER IS: 6477-1983 ,UNLESS OTHERWISE SPECIFIED			
PARTY'S NAME	GENERAL CATEGORY	SCALE	1:1 & 3:1
PARTY'S DRAWING No.	NIL	WEIGHT kg/m	1.051
ALLOY & TEMPER	HE9 WP	SECTION No.	20857
LENGTH	3658 mm.	DRAWING No.	20857
DESCRIPTION	WINDOW SECTION		