

8964

12523

20861

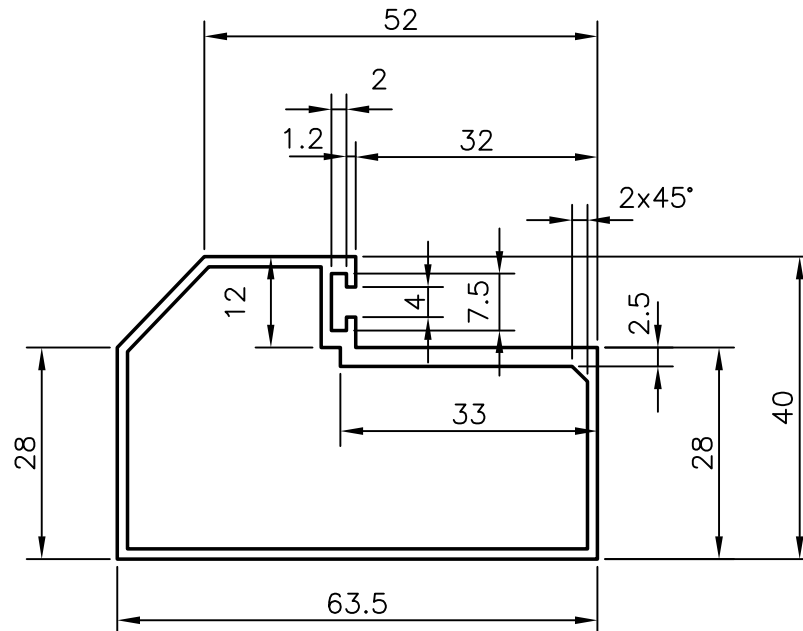

GENERAL WALL THICKNESS :- 1.35 mm.,  
UNLESS OTHERWISE SPECIFIED

## *JINDAL ALUMINIUM LTD.*

*BANGALORE-560073*

<i>JINDAL ALUMINIUM LTD.</i>		NAME	DATE
<i>BANGALORE-560073</i>		DRAWN	D.SRIVASTAVA 17-07-98
1. ALL DIMENSIONS ARE IN mm.		CHECKED	
2. ROUND OFF ALL SHARP CORNERS WITH 0.4 mm.		APPROVED	
3. TOLERANCES WILL BE AS PER IS: 6477-1983 ,UNLESS OTHERWISE SPECIFIED		SCALE	1:1
PARTY'S NAME	GENERAL CATEGORY	WEIGHT kg/m	0.858
PARTY'S DRAWING No.	NIL	SECTION No.	20861
ALLOY & TEMPER	HE9 WP	DRAWING No.	20861
LENGTH	3658 mm.		
DESCRIPTION	ARCHITECTURAL SECTION		