

8972
11878
20868

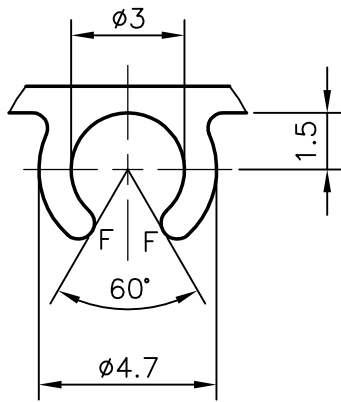

A (5:1)

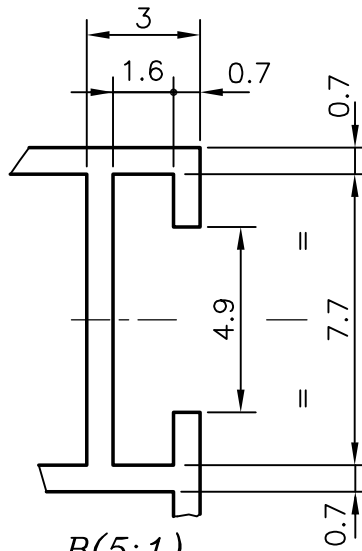

B(5:1)

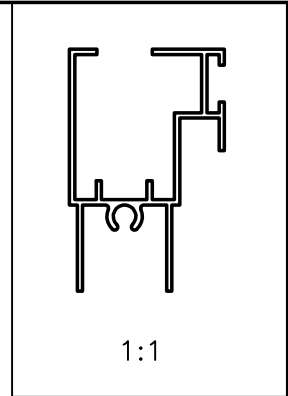

1:1

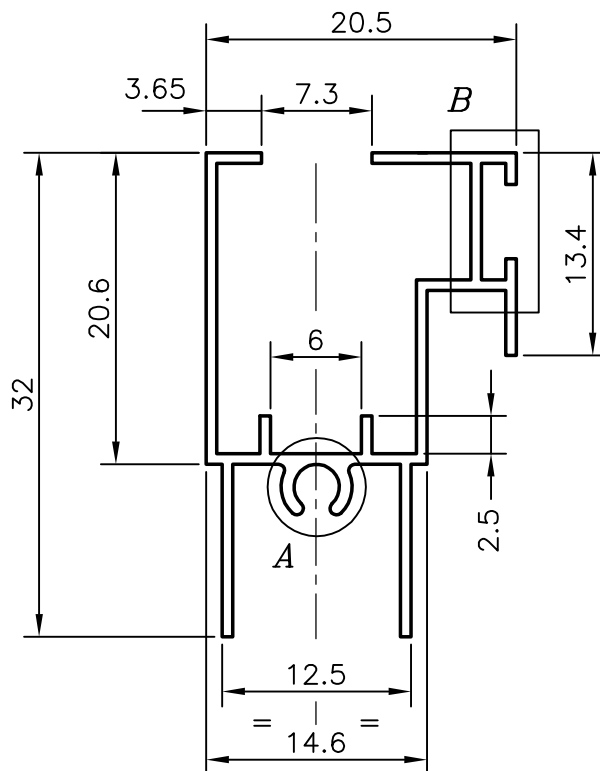

GENERAL WALL THICKNESS :- 0.7 mm
F = FULL RADIUS (2)

JINDAL ALUMINIUM LTD.
BANGALORE-560073

	NAME	DATE
DRAWN	D.SRIVASTAVA	23-09-98
CHECKED		
APPROVED		

1. ALL DIMENSIONS ARE IN mm.
2. ROUND OFF ALL SHARP CORNERS WITH 0.4 mm.
3. TOLERANCES WILL BE AS PER IS: 3965-1981 ,UNLESS OTHERWISE SPECIFIED

PARTY'S NAME	GENERAL CATEGORY	SCALE	2:1
PARTY'S DRAWING No.	NIL	WEIGHT kg/m	0.220
ALLOY & TEMPER	HE9 WP	SECTION No.	20868
LENGTH	3658 mm.	DRAWING No.	20868
DESCRIPTION	WINDOW SECTION		