

8976

12531

20872

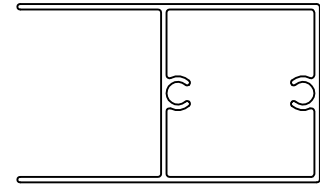

F = RADII FULL (6)

1:1 (TRUE SCALE)

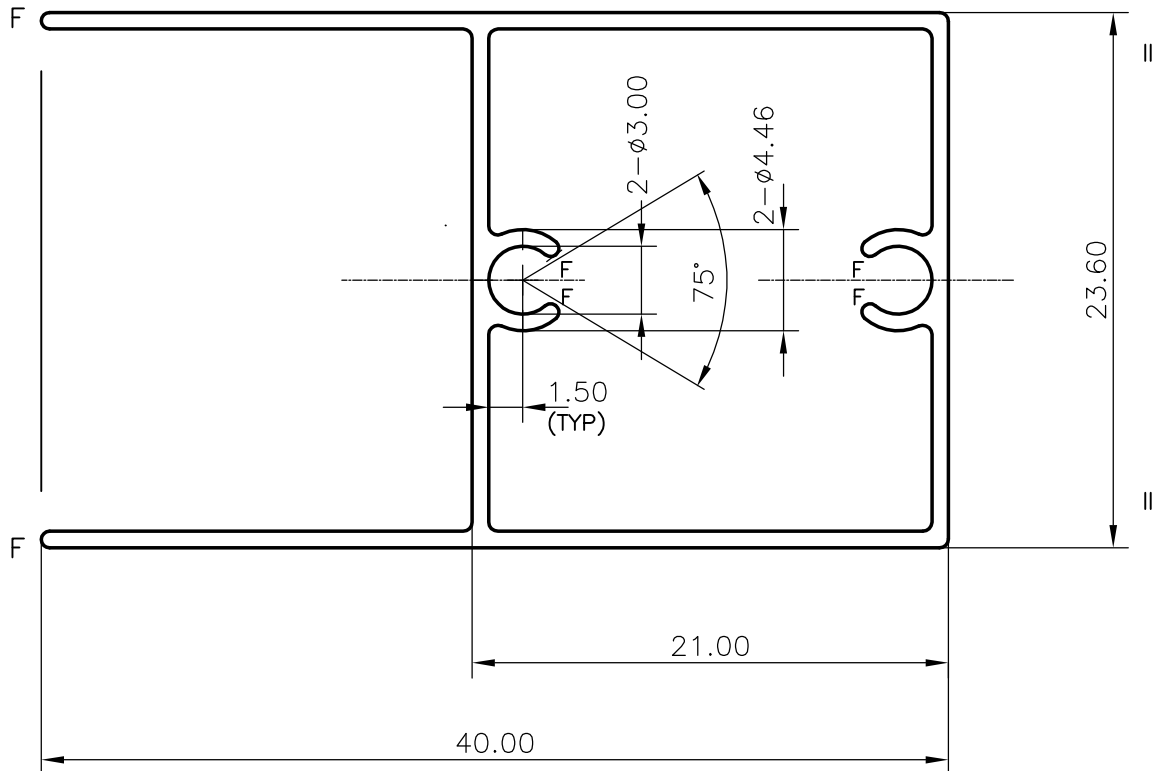

1. GENERAL WALL THICKNESS :- 0.73 mm.
2. 3658 mm. LONG PIECES IN 100 kgs. :- 100 (AVERAGE)

JINDAL ALUMINIUM LTD.

BANGALORE-560073

NAME

DATE

DRAWN

P,KULKARNI

11-8-99

1. ALL DIMENSIONS ARE IN mm.
2. ROUND OFF ALL SHARP CORNERS WITH 0.4 mm.
3. TOLERANCES WILL BE AS PER IS: 6477-1983 UNLESS OTHERWISE SPECIFIED

CHECKED

APPROVED

PARTY'S NAME

GENERAL CATEGORY

SCALE

3:1

PARTY'S DRAWING No.

8952 JINDAL MODIFIED.

WEIGHT kg/m

0.273

ALLOY & TEMPER

HE9 WP

SECTION No.

20872

LENGTH

3658 mm.

DRAWING No.

DESCRIPTION

WINDOW SECTION

20872