

8980

12068

20876

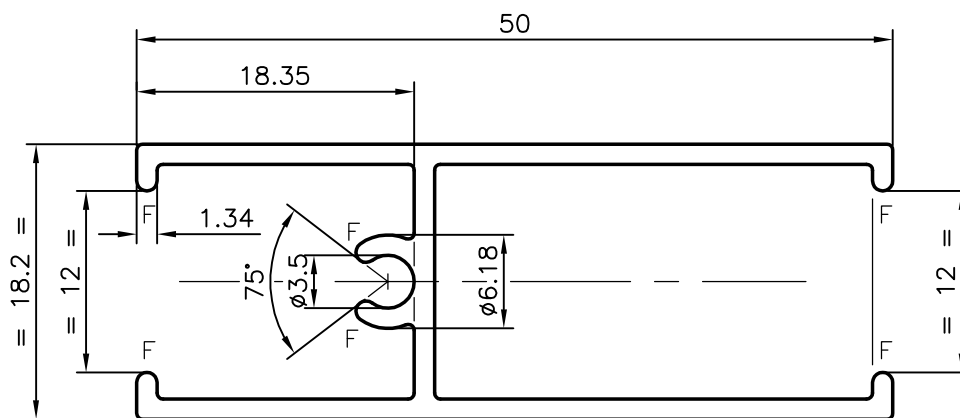
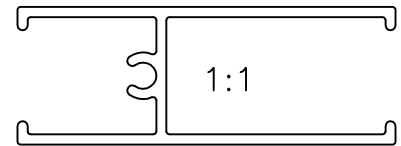

GENERAL WALL THICKNESS = 1.34 mm.

F = FULL RADII (6)



SYMBOL OF QUALITY
AN ISO 9001 COMPANY

JINDAL ALUMINIUM LTD.
BANGALORE-560073 (INDIA)

	NAME	DATE
DRAWN	MALINGAPPA	29-09-2005
CHECKED		
APPROVED		

1. ALL DIMENSIONS ARE IN mm.
2. ROUND OFF ALL SHARP CORNERS WITH 0.50 mm.
3. TOLERANCES WILL BE AS PER IS:3965-1981 UNLESS OTHERWISE SPECIFIED

SCALE	2:1
AREA mm ²	174.717
PERIMETER mm.	256.893
WEIGHT kg/m	0.471

PARTY'S NAME GENERAL CATEGORY, MUMBAI MARKET

PARTY'S DRAWING No. 8961 JAL MODIFIED

ALLOY & TEMPER HE9 WP

DESCRIPTION WINDOW SECTION

DRAWING No.	SECTION No.
8980	8980
12068	12068
20876	20876