

X015
8986
12536
20882

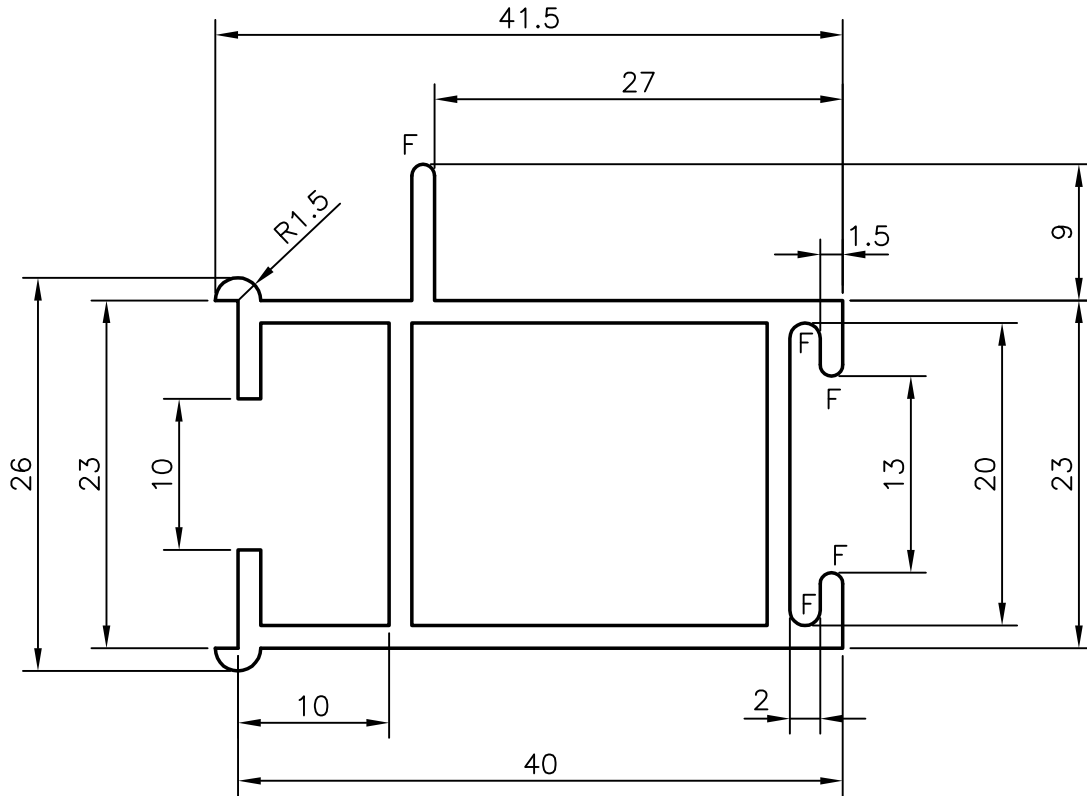
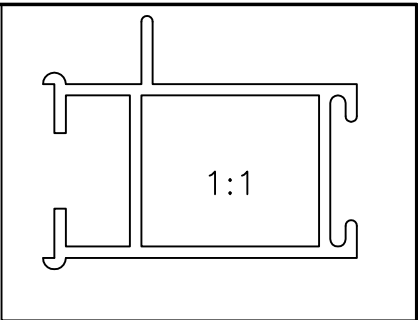

GENERAL WALL THICKNESS:- 1.50 mm.  
 F = FULL RADIUS (5)

<b>JINDAL ALUMINIUM LTD.</b> <i>BANGALORE-560073</i>		NAME	DATE
		DRAWN	R.D.Sharma 27-08-97
1. ALL DIMENSIONS ARE IN mm. 2. ROUND OFF ALL SHARP CORNERS WITH 0.4 mm. 3. TOLERANCES WILL BE AS PER IS: 6477-1983 ,UNLESS OTHERWISE SPECIFIED		CHECKED	
		APPROVED	
		SCALE	1:1 & 2:1
PARTY'S NAME	A.S.B. & SONS, MADURAI	WEIGHT kg/m	0.748
PARTY'S DRAWING No.	X-9132	SECTION No.	20882
ALLOY & TEMPER	HE9 WP	DRAWING No.	20882
LENGTH	3658 mm. & 2743 mm.		
DESCRIPTION	WINDOW SECTION		