

8992

12070

20888

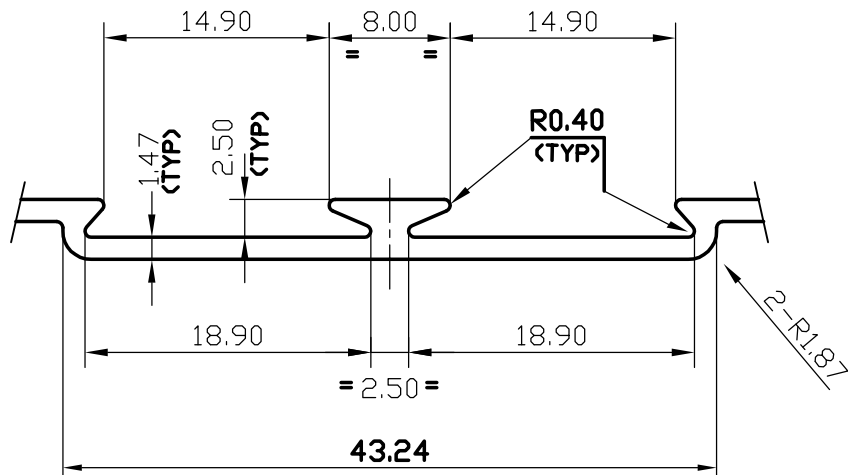

SCALE 2:1

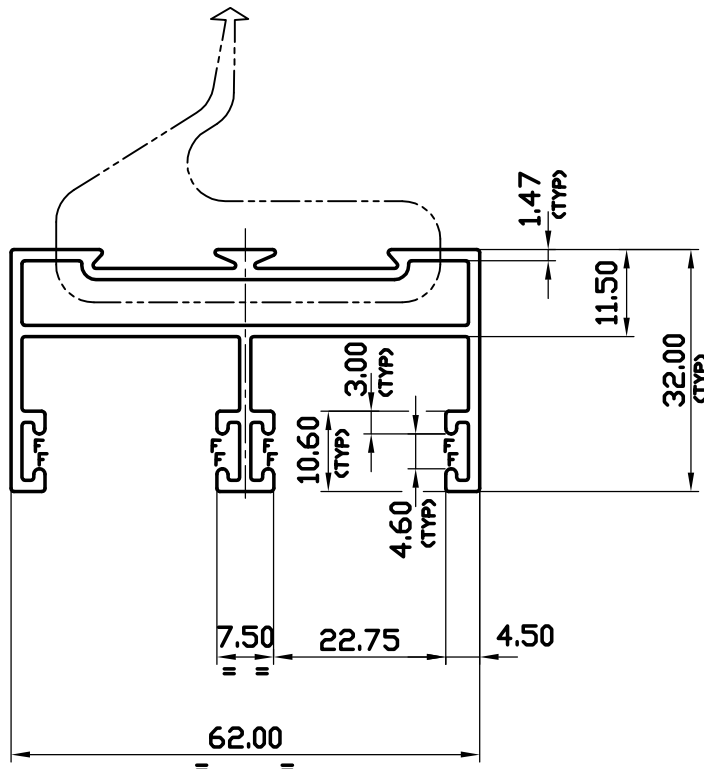

F = RADII FULL (8 PLACES)

GENERAL WALL THICKNESS 1.47 mm.



SYMBOL OF QUALITY
AN ISO 9002 COMPANY

JINDAL ALUMINIUM LTD.
BANGALORE-560073 (INDIA)

	NAME	DATE
DRAWN	P,KULKARNI	27-4-2000
CHECKED		
APPROVED		
SCALE	1:1	
WEIGHT kg/m	1.005	
SECTION No.	20888	
DRAWING No.	20888	

1. ALL DIMENSIONS ARE IN mm.
2. ROUND OFF ALL SHARP CORNERS WITH 0.40 mm.
3. TOLERANCES WILL BE AS PER I.S. 6477-1983 UNLESS OTHERWISE SPECIFIED

PARTY'S NAME **GENERAL CATEGORY (BANGALORE MARKET)**

PARTY'S DRAWING No. **AS PER SAMPLE & REQ 3.60 KG/12FT**

ALLOY & TEMPER **HE9 WP**

DESCRIPTION **WINDOW SECTION**