

8997

12073

20893

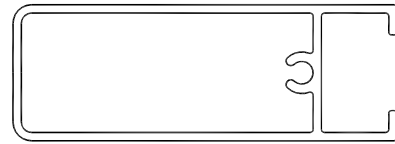

1:1

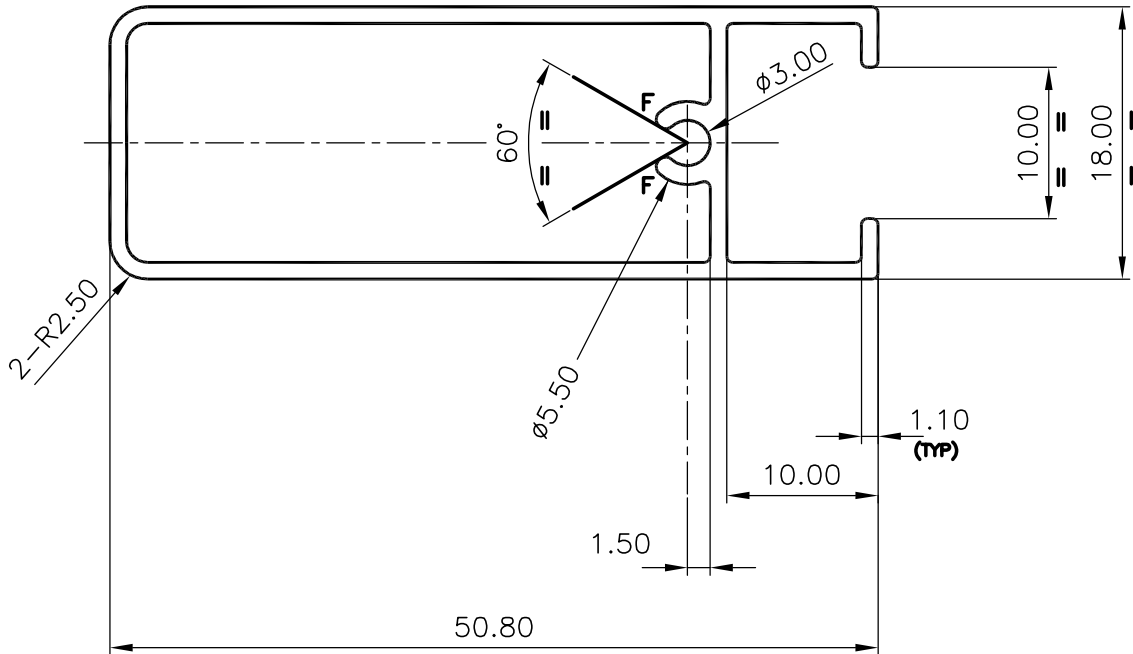

GENERAL WALL THICKNESS 1.10 mm
F = RADII FULL (2-PLACES)



SYMBOL OF QUALITY
AN ISO 9002 COMPANY

JINDAL ALUMINIUM LTD.
BANGALORE-560073 (INDIA)

| | NAME | DATE |
|---------------------|--------------------------------|-----------|
| DRAWN | P,KULKARNI | 20-6-2000 |
| CHECKED | | |
| APPROVED | | |
| SCALE | 2:1 | |
| WEIGHT kg/m | 0.434 | |
| PARTY'S NAME | GENERAL CATEGORY (PUNE MARKET) | |
| PARTY'S DRAWING No. | AS PER SKETCH | |
| ALLOY & TEMPER | HE9 WP | |
| DESCRIPTION | WINDOW SECTION | |