

8998

12542

20894

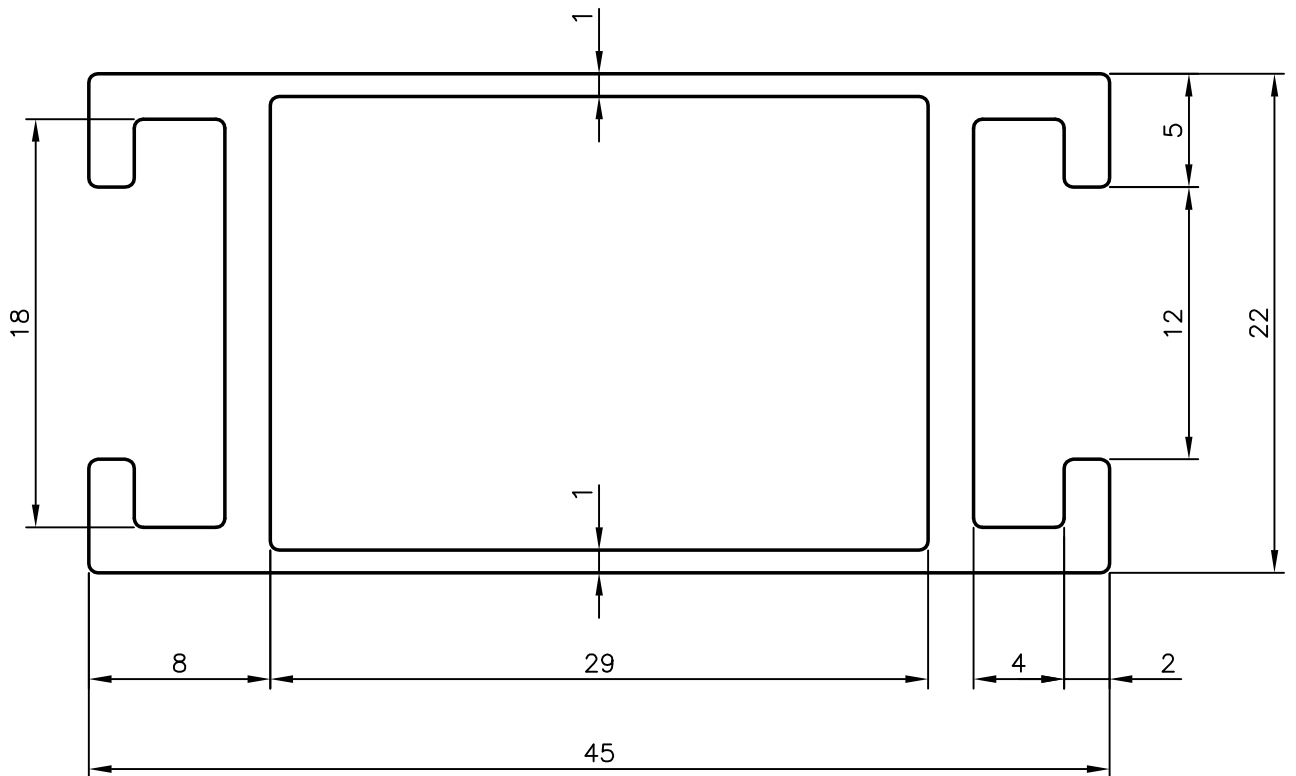

GENERAL WALL THICKNESS = 2.00 mm
UNLESS OTHERWISE SPECIFIED



SYMBOL OF QUALITY
AN ISO 9001 COMPANY

JINDAL ALUMINIUM LTD.
BANGALORE-560073 (INDIA)

	NAME	DATE
DRAWN	PRASANNA.H.	11-02-2007
CHECKED		
APPROVED		

1. ALL DIMENSIONS ARE IN mm.
2. ROUND OFF ALL SHARP CORNERS WITH 0.40 mm.
3. TOLERANCES WILL BE AS PER IS:6477-1983 UNLESS OTHERWISE SPECIFIED

SCALE	3:1
AREA mm ²	217.966
PERIMETER mm.	178.738
WEIGHT kg/m	0.588

PARTY'S NAME	FABRICANA INTERIOR DECORATORS, BANGALORE
PARTY'S DRAWING No.	NIL
ALLOY & TEMPER	HE9 WP
DESCRIPTION	WINDOW SECTION

DRAWING No.	SECTION No.
8998	8998
12542	12542
20894	20894