

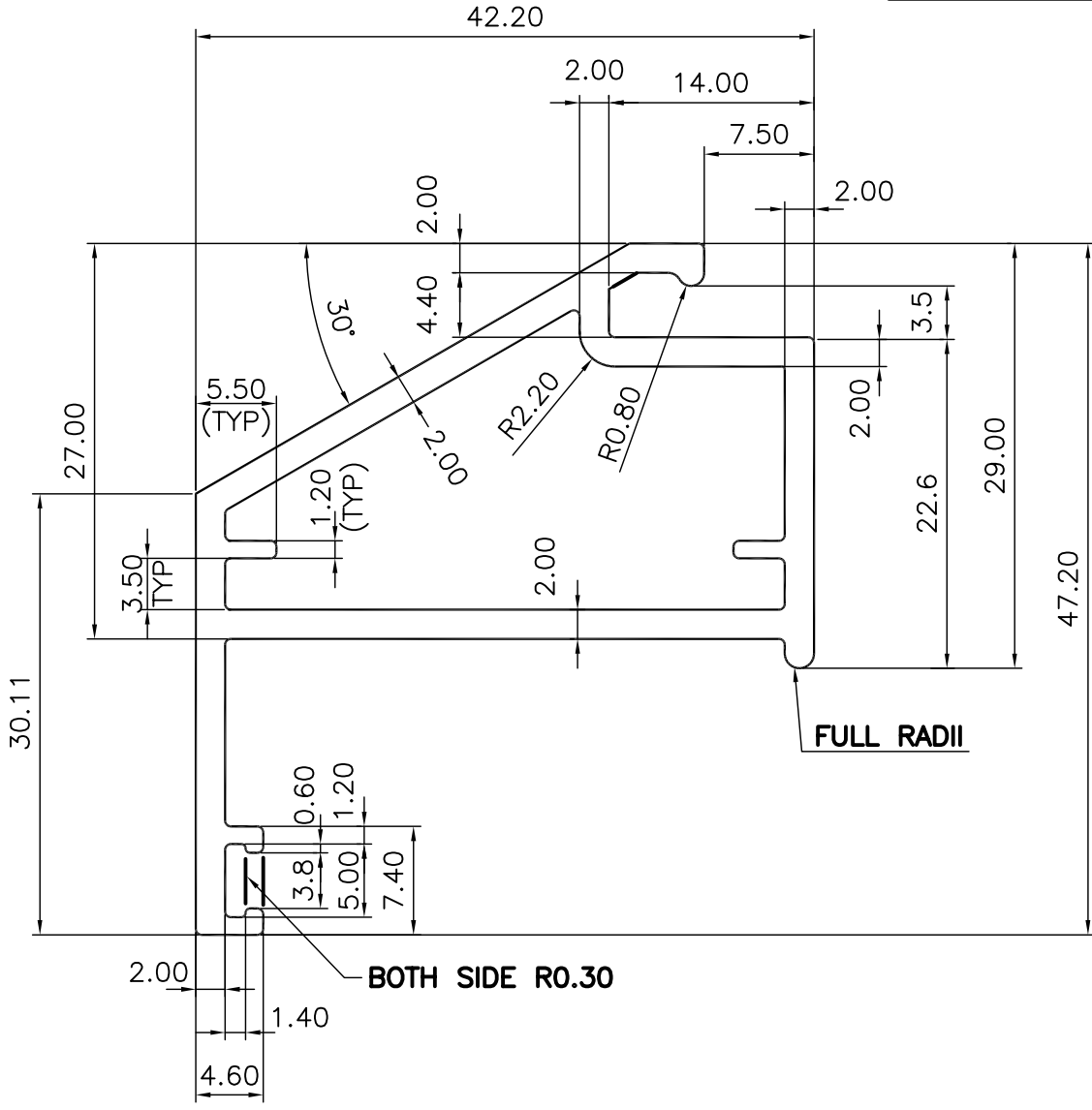

S562
9305
12551
20901

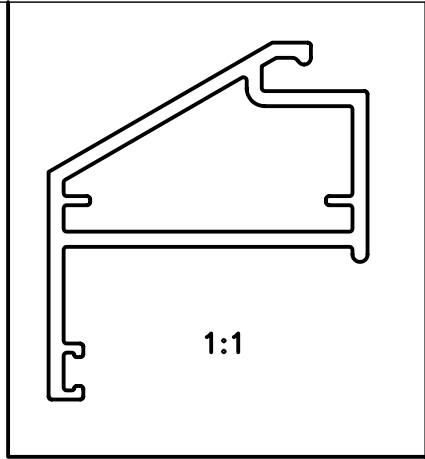

| | | | |
|--|--|--------------|---------------------|
|  SYMBOL OF QUALITY AN ISO 9002 COMPANY | JINDAL ALUMINIUM LTD. BANGALORE-560073 (INDIA) | NAME | DATE |
| | | DRAWN | BASAVARAJ 21-8-2000 |
| 1. ALL DIMENSIONS ARE IN mm. 2. ROUND OFF ALL SHARP CORNERS WITH 0.40 mm. 3. TOLERANCES WILL BE AS PER I.S: 6477-1983 UNLESS OTHERWISE SPECIFIED | | CHECKED | |
| | | APPROVED | |
| | | SCALE | 2:1 |
| PARTY'S NAME | RADHA SOAMI SATSANG BEAS, BEAS. | WEIGHT kg/m | 0.827 |
| PARTY'S DRAWING No. | AS PER SAMPLE (BM 20011) | SECTION No. | 20901 |
| ALLOY & TEMPER | HE9 WP | DRAWING No. | |
| DESCRIPTION | SHELTER | 20901 | |