

X025
9321
12564
20917

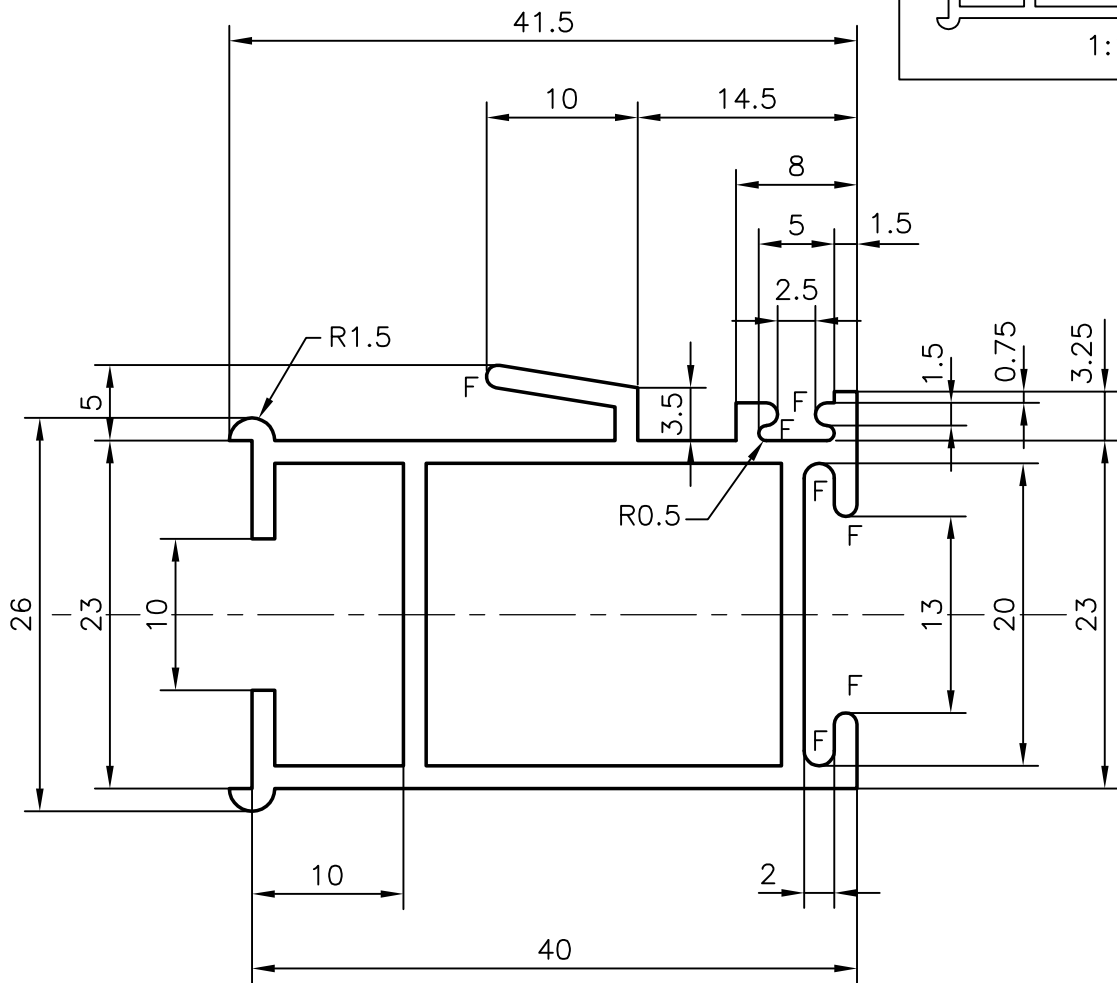
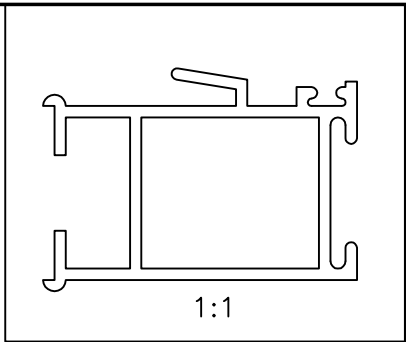

GENERAL WALL THICKNESS :- 1.50 mm.
 F = FULL RADIUS (9)

JINDAL ALUMINIUM LTD. <i>BANGALORE-560073</i>		NAME	DATE
		DRAWN	R.D.Sharma 03-01-98
1. ALL DIMENSIONS ARE IN mm. 2. ROUND OFF ALL SHARP CORNERS WITH 0.4 mm. 3. TOLERANCES WILL BE AS PER IS: 6477-1983 ,UNLESS OTHERWISE SPECIFIED		CHECKED	
		APPROVED	
		SCALE	1:1 & 2:1
PARTY'S NAME	A.S.B. & SONS, MADURAI	WEIGHT kg/m	0.656
PARTY'S DRAWING No.	X-9133	SECTION No.	20917
ALLOY & TEMPER	HE9 WP	DRAWING No.	20917
LENGTH	3658 mm. & 2743 mm.		
DESCRIPTION	WINDOW SECTION		