

9325

12349

20921

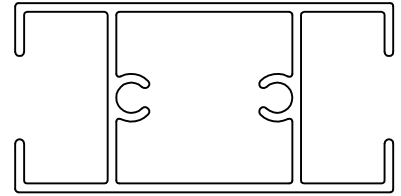

SCALE 1:1

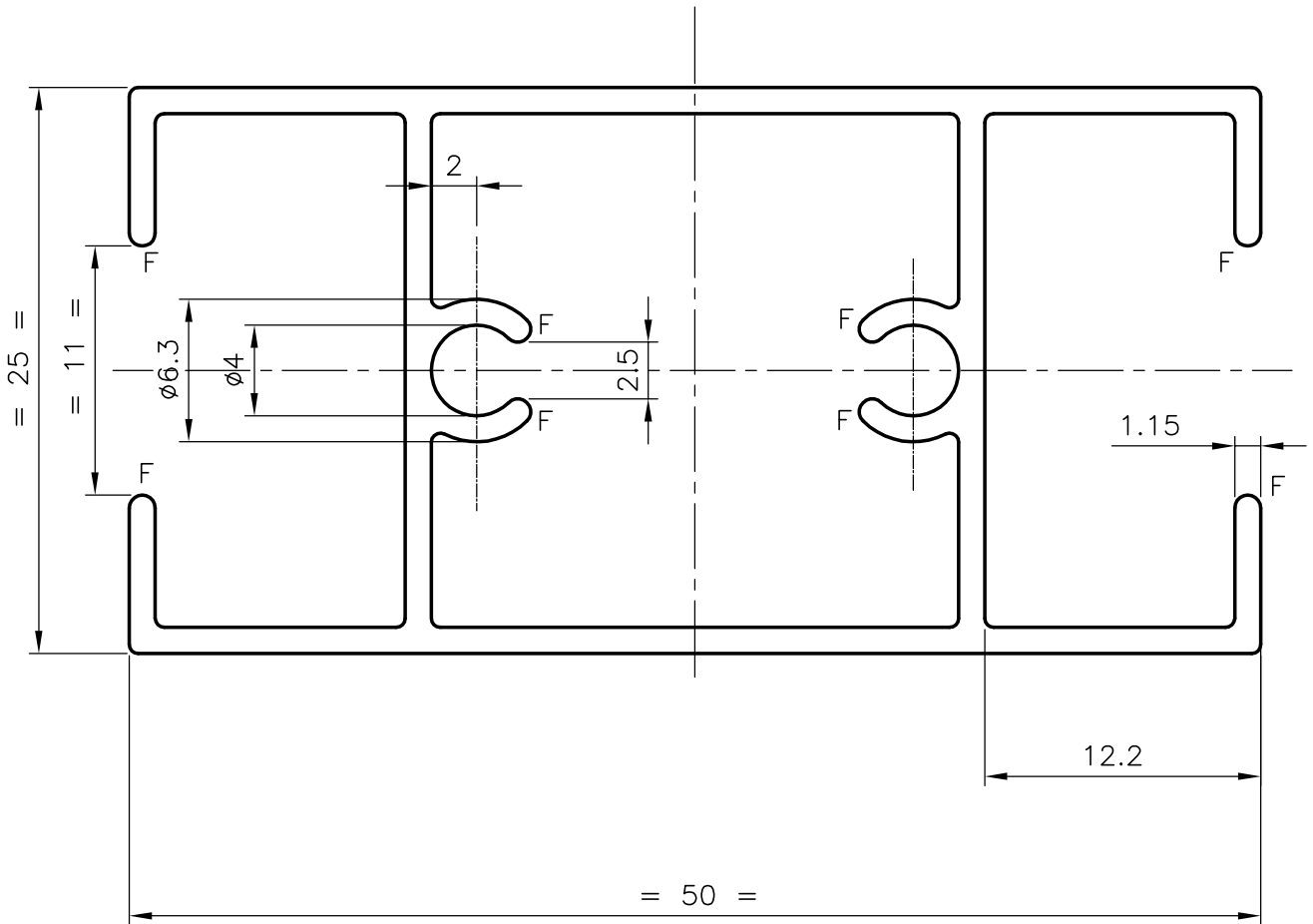

GENERAL WALL THICKNESS 1.15 mm

F = RADII FULL (8)



SYMBOL OF QUALITY
AN ISO 9002 COMPANY

JINDAL ALUMINIUM LTD.

BANGALORE-560073 (INDIA)

	NAME	DATE
DRAWN	RANGASWAMY	25-02-01
CHECKED		
APPROVED		

1. ALL DIMENSIONS ARE IN mm.
2. ROUND OFF ALL SHARP CORNERS WITH 0.40 mm.
3. TOLERANCES WILL BE AS PER IS:6477-1983 UNLESS OTHERWISE SPECIFIED

SCALE	3:1
WEIGHT kg/m	0.584

PARTY'S NAME	GENERAL CATEGORY (MUMBAI MARKET)	
PARTY'S DRAWING No.	AS PER PARTY SKETCH	
ALLOY & TEMPER	HE9 WP	LENGTH: 3658 mm
DESCRIPTION	WINDOW SECTION	

SECTION No.	20921
DRAWING No.	20921