

9327

12568

20923

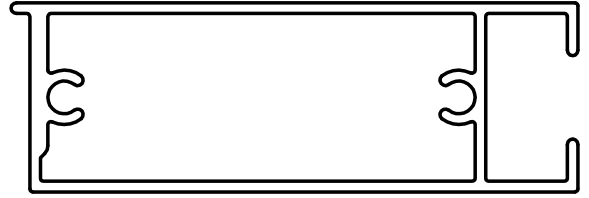

.SCALE 1:1

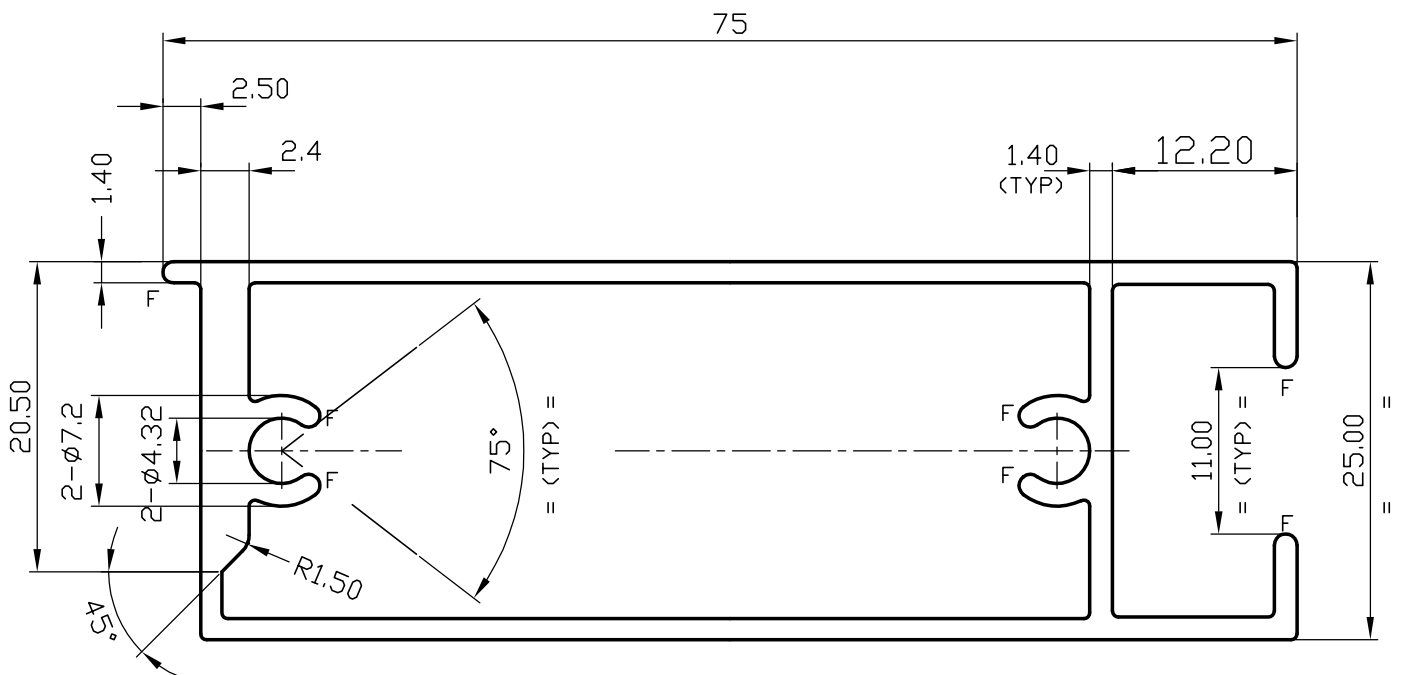

GENERAL WALL THICKNESS 1.4 mm

No OFF PIECES IN 100 kgs 30 (AVERAGE)

F = RADII FULL (7)



SYMBOL OF QUALITY
AN ISO 9002 COMPANY

JINDAL ALUMINIUM LTD.
BANGALORE-560073 (INDIA)

NAME

DATE

DRAWN

RANGASWAMY

25-02-01

CHECKED

APPROVED

SCALE

2:1

WEIGHT kg/m

0.895

SECTION No.

20923

DRAWING No.

20923

1. ALL DIMENSIONS ARE IN mm.
2. ROUND OFF ALL SHARP CORNERS WITH 0.40 mm.
3. TOLERANCES WILL BE AS PER IS:6477-1983 UNLESS OTHERWISE SPECIFIED

PARTY'S NAME

GENERAL CATEGORY (MUMBAI MARKET)

PARTY'S DRAWING No.

AS PER SAMPLE (WITH CORRECTION)

ALLOY & TEMPER

HE9 WP

LENGTH:

3658 mm

DESCRIPTION

WINDOW SECTION