

9330

12074

20926

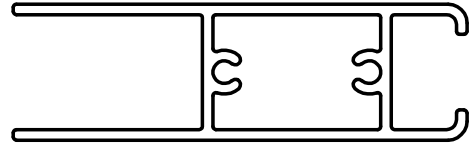

SCALE 1:1

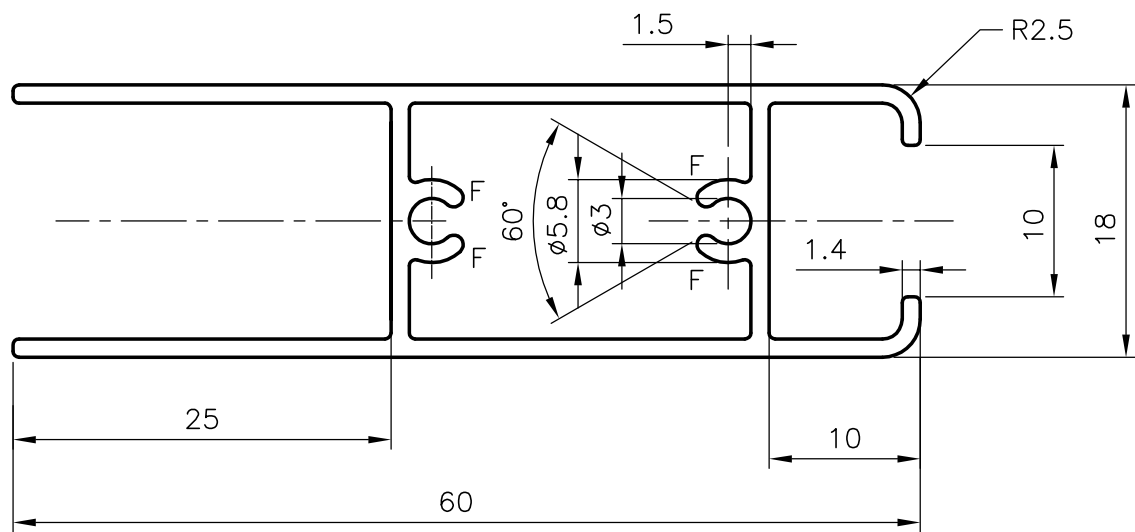

GENERAL WALL THICKNESS:-1.4mm
F=FULL RADII (4-PLCS)



SYMBOL OF QUALITY
AN ISO 9002 COMPANY

JINDAL ALUMINIUM LTD.
BANGALORE-560073 (INDIA)

NAME

DATE

DRAWN

RANGASWAMY

22-05-01

CHECKED

APPROVED

1. ALL DIMENSIONS ARE IN mm.
2. ROUND OFF ALL SHARP CORNERS WITH 0.40 mm.
3. TOLERANCES WILL BE AS PER IS:6477-1983 UNLESS OTHERWISE SPECIFIED

SCALE

2:1 & 1:1

PARTY'S NAME

GENERAL CATEGORY (MUMBAI MARKET)

WEIGHT kg/m

0.641

PARTY'S DRAWING No.

AS PER SKETCH

SECTION No.

20926

ALLOY & TEMPER

HE9 WP

DRAWING No.

20926

DESCRIPTION

WINDOW SECTION