

P-3467

9336

12572

20932

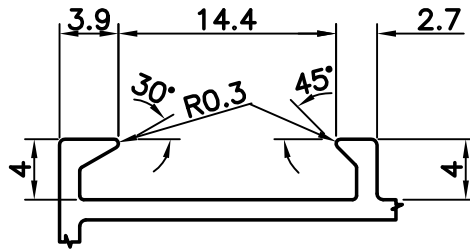

- A -

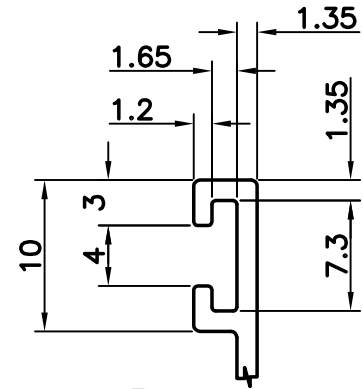

- B -

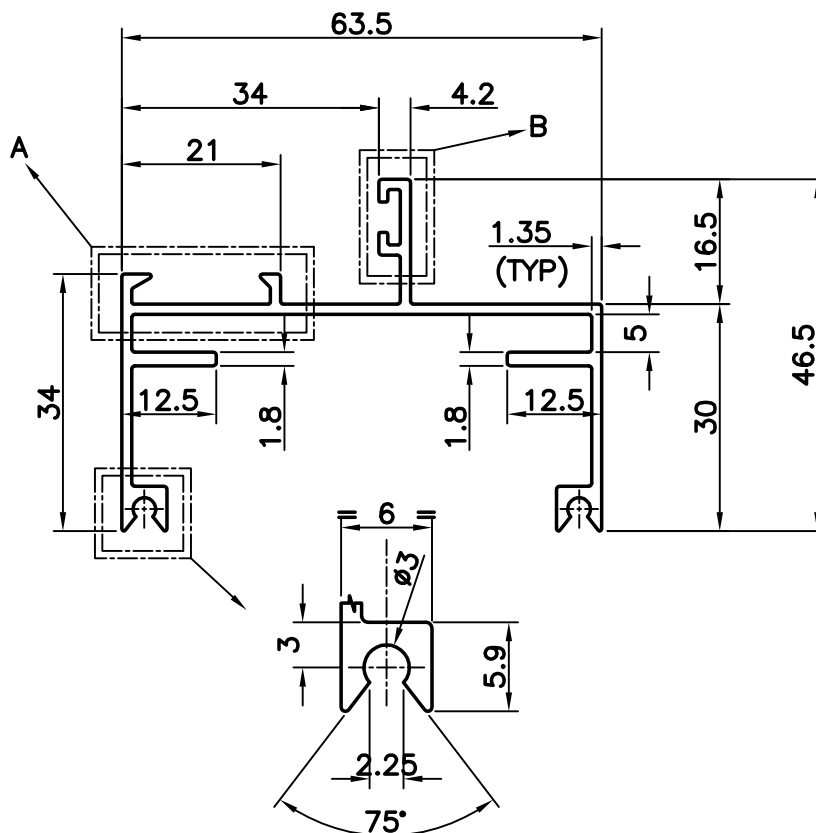

GENERAL WALL THICKNESS : -1.35 mm



SYMBOL OF QUALITY
AN ISO 9002 COMPANY

JINDAL ALUMINIUM LTD.
BANGALORE-560073 (INDIA)

	NAME	DATE
DRAWN	SUDIP ROY	07.08.2001
CHECKED		
APPROVED		

1. ALL DIMENSIONS ARE IN mm.
2. ROUND OFF ALL SHARP CORNERS WITH 0.40 mm.
3. TOLERANCES WILL BE AS PER IS: 3965-1981 UNLESS OTHERWISE SPECIFIED

PARTY'S NAME	GENERAL CATEGORY.; MUMBAI MARKET	SCALE	1:1 & 2:1
PARTY'S DRAWING No.	ASPER SAMPLE	WEIGHT kg/m	0.758
ALLOY & TEMPER	HE9 WP	PERIMETER mm	387.373
DESCRIPTION	WINDOW SECTION	SECTION No.	20932
		DRAWING No.	20932