

P-3552

9338

12574

20934

GENERAL WALL THICKNESS = 1.5mm
F = FULL RADII (2 PLACES)

DETAIL "A"
SCALE 3:1

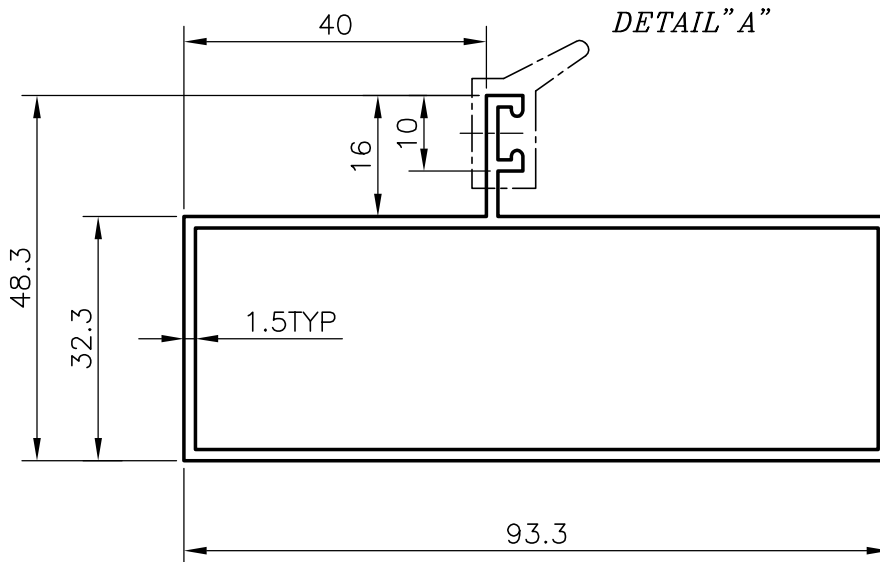
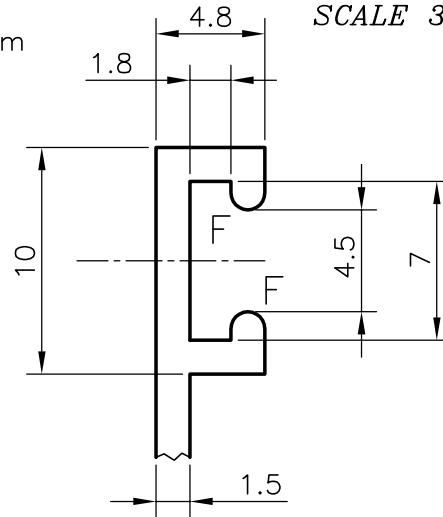

SYMBOL OF QUALITY
AN ISO 9002 COMPANY

JINDAL ALUMINIUM LTD.
BANGALORE-560073 (INDIA)

NAME DATE

DRAWN RAGHAVENDRA 01-10-01

CHECKED

APPROVED

SCALE 1:1

WEIGHT kg/m 1.093

PERIMETER 300.11mm

SECTION No. 20934

DRAWING No. 20934

1. ALL DIMENSIONS ARE IN mm.
2. ROUND OFF ALL SHARP CORNERS WITH 0.40 mm.
3. TOLERANCES WILL BE AS PER I.S 6477-1983 UNLESS OTHERWISE SPECIFIED

PARTY'S NAME GENERAL CATEGORY ,. BANGALORE MARKET

PARTY'S DRAWING No. AS PER SAMPLE

ALLOY & TEMPER HE9 WP

DESCRIPTION WINDOW SECTION