

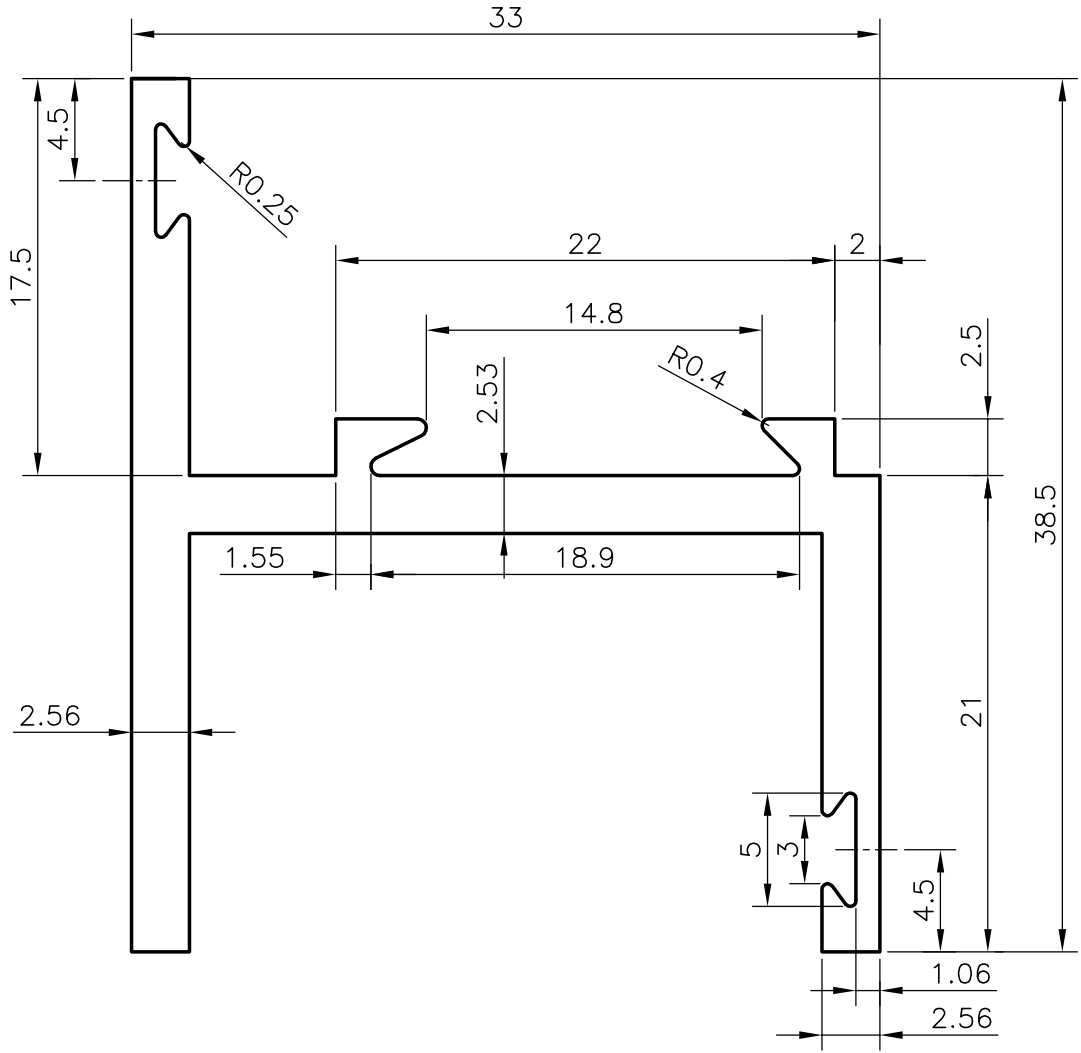

9353
11815
20948

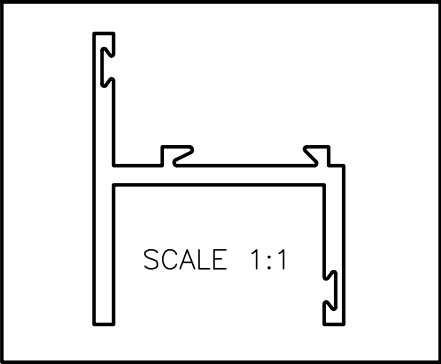

NO OF PIECES IN 100 kgs:- 45 (AVERAGE)

 SYMBOL OF QUALITY AN ISO 9002 COMPANY	JINDAL ALUMINIUM LTD. BANGALORE-560073 (INDIA)	NAME	DATE
		DRAWN	RAGHAVENDRA 06-12-01
1. ALL DIMENSIONS ARE IN mm. 2. ROUND OFF ALL SHARP CORNERS WITH 0.40 mm. 3. TOLERANCES WILL BE AS PER I.S 3965-1981 UNLESS OTHERWISE SPECIFIED		CHECKED	
		APPROVED	
PARTY'S NAME		SCALE	3:1 & 1:1
PARTY'S DRAWING No.		WEIGHT kg/m	0.606
ALLOY & TEMPER		PERIMETER	206.45mm
DESCRIPTION		SECTION No.	20948
		DRAWING No.	20948