

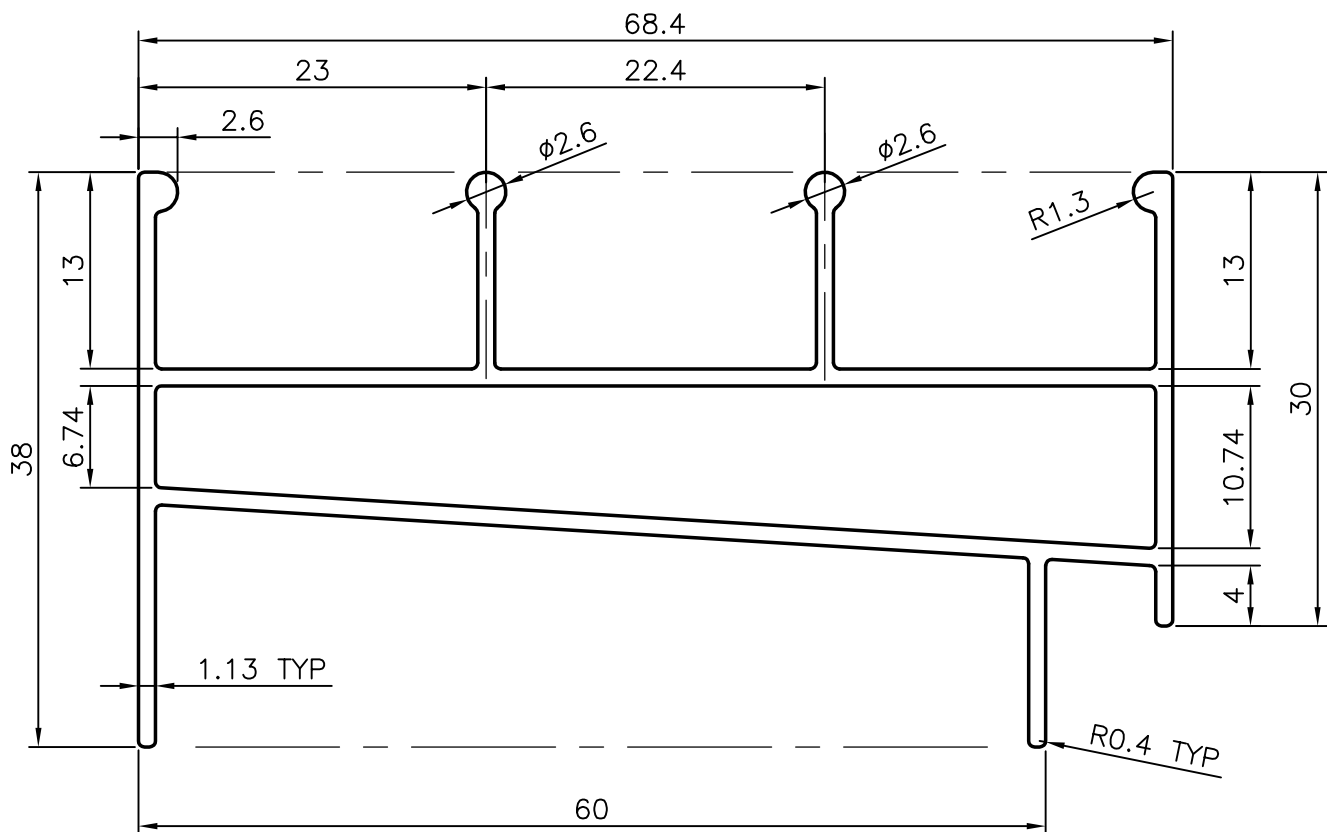

9360
11888
20955

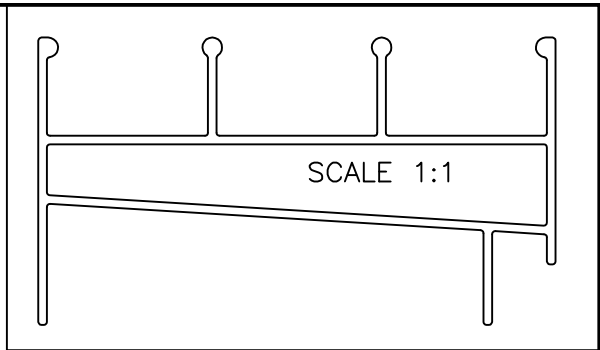

NOTE:- 1. GENERAL WALL THICKNESS = 1.13 mm
 2. NO. OF PIECES IN 100 kgs = 36 (AVERAGE)

 SYMBOL OF QUALITY AN ISO 9001 COMPANY	JINDAL ALUMINIUM LTD. BANGALORE-560073 (INDIA)	DRAWN	NAME	DATE
		CHECKED	PRASANN.H	27-12-2006
1. ALL DIMENSIONS ARE IN mm. 2. ROUND OFF ALL SHARP CORNERS WITH 0.40 mm. 3. TOLERANCES WILL BE AS PER IS:6477-1983 UNLESS OTHERWISE SPECIFIED		APPROVED		
		SCALE		2:1
PARTY'S NAME -		AREA mm ²		281.238
		PERIMETER mm.		329.751
PARTY'S DRAWING No. LIGTER SECTION OF 8686		WEIGHT kg/m		0.759
		DRAWING No.	SECTION No.	
ALLOY & TEMPER HE9 WP		9360		9360
		11888		11888
DESCRIPTION WINDOW SECTION		20955		20955