

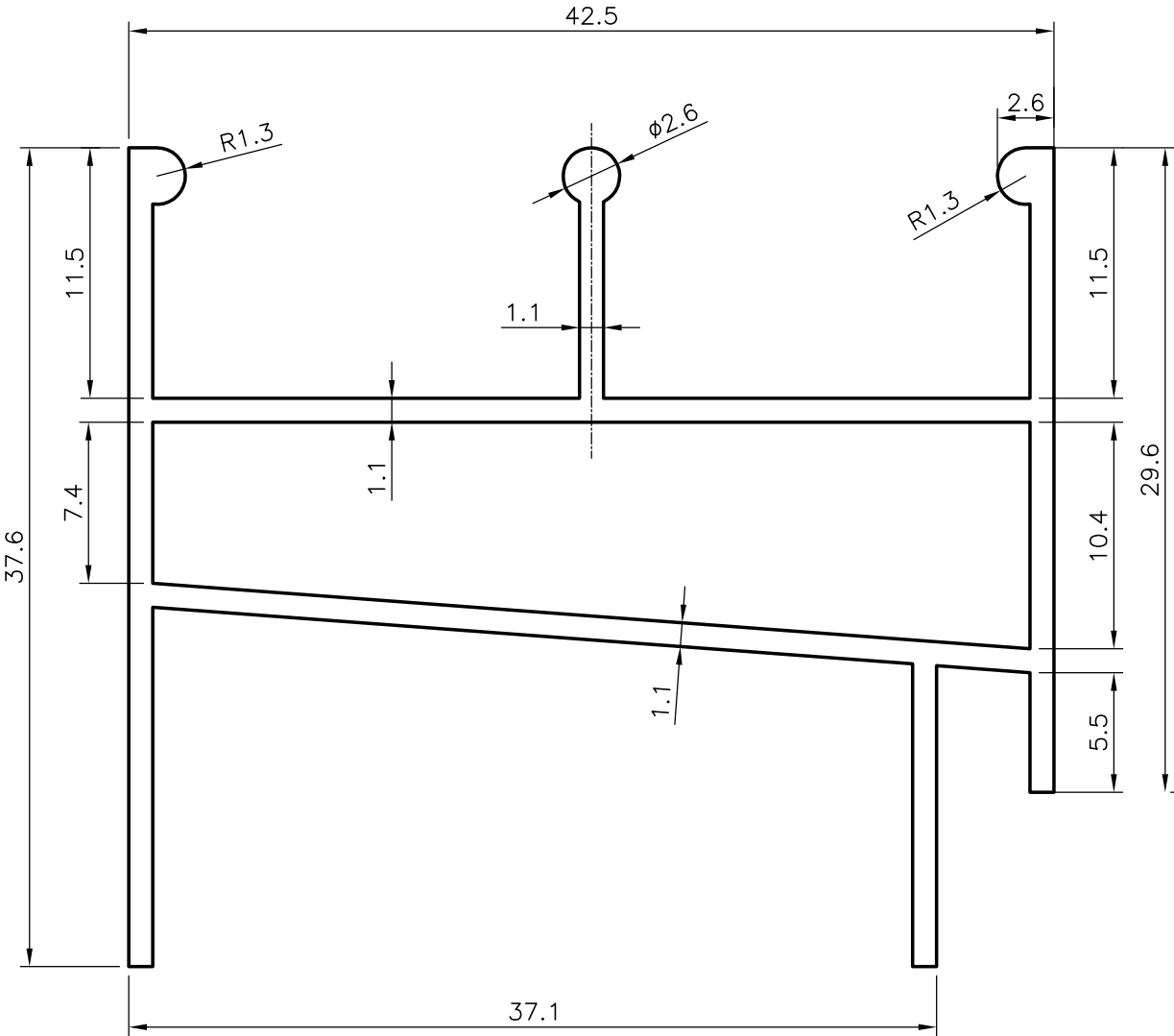

9364
11964
20959

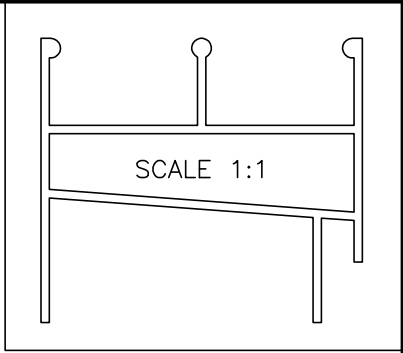

GENERAL WALL THICKNESS = 1.10mm
 NO. OF PIECES IN 100 kgs = 50 (AVERAGE)

 SYMBOL OF QUALITY AN ISO 9001 COMPANY	JINDAL ALUMINIUM LTD. BANGALORE-560073 (INDIA)	DRAWN	NAME	DATE
		CHECKED	RAGHAVENDRA	23-12-2006
1. ALL DIMENSIONS ARE IN mm. 2. ROUND OFF ALL SHARP CORNERS WITH 0.40 mm. 3. TOLERANCES WILL BE AS PER IS:6477-1983 UNLESS OTHERWISE SPECIFIED		APPROVED		
		SCALE		3:1
PARTY'S NAME -		AREA mm ²		199.437
		PERIMETER mm.		252.796
PARTY'S DRAWING No. LIGHTER SECTION OF 8690		WEIGHT kg/m		0.538
		DRAWING No.	SECTION No.	
ALLOY & TEMPER HE9 WP		9364		9364
		11964		11964
DESCRIPTION WINDOW SECTION		20959		20959