

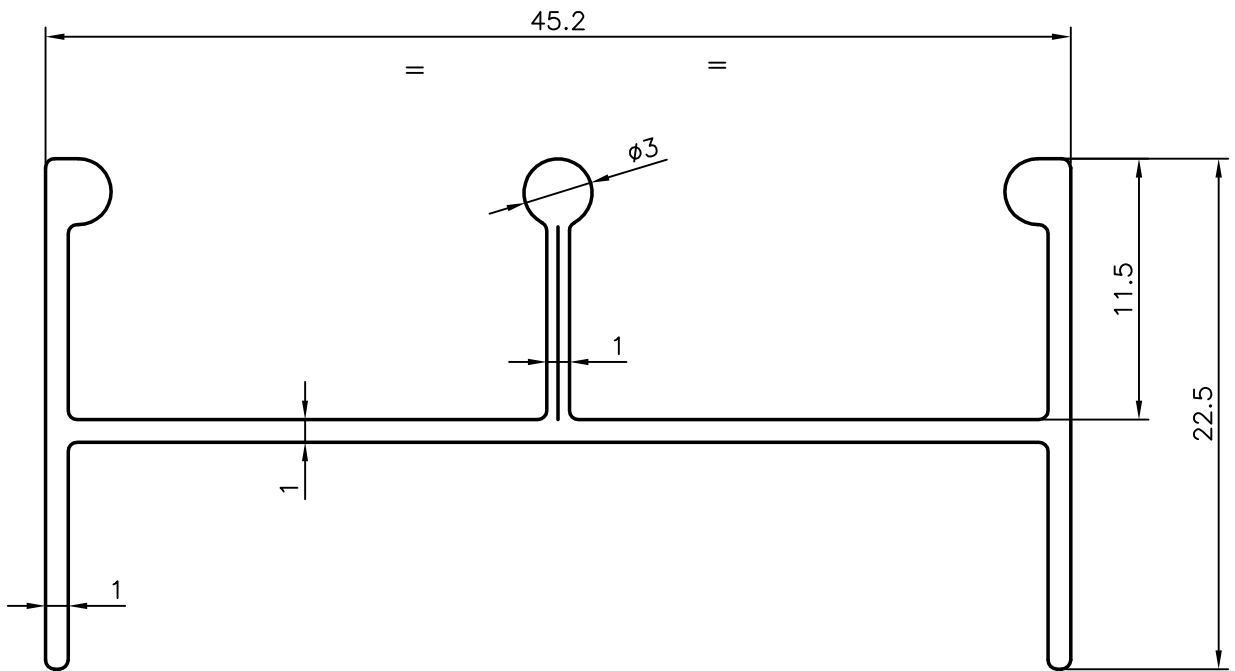

9366
11866
20961

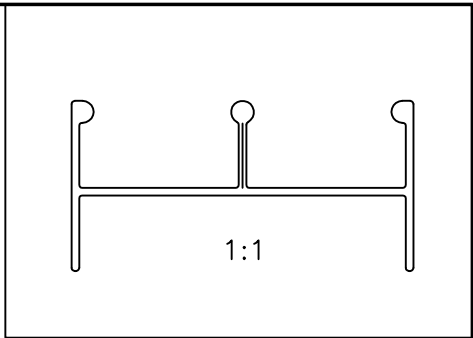

GENERAL WALL THICKNESS :- 1.00 mm  
 NO OF PIECES IN 100 kgs :- 90 (AVERAGE)

 SYMBOL OF QUALITY AN ISO 9001 COMPANY	<b>JINDAL ALUMINIUM LTD.</b> BANGALORE-560073 (INDIA)		NAME	DATE
		DRAWN	PRASHANT	10-11-2006
1. ALL DIMENSIONS ARE IN mm. 2. ROUND OFF ALL SHARP CORNERS WITH 0.40 mm. 3. TOLERANCES WILL BE AS PER IS:3965-1981 UNLESS OTHERWISE SPECIFIED		CHECKED		
		APPROVED		
PARTY'S NAME -		SCALE		3:1 & 1:1
		AREA mm <sup>2</sup>		113.102
PARTY'S DRAWING No. LIGHTER SECTION OF 8693		PERIMETER mm.		208.09
		WEIGHT kg/m		0.304
ALLOY & TEMPER HE9 WP		DRAWING No.		SECTION No.
		9366		9366
DESCRIPTION WINDOW SECTION		11866		11866
		20961		20961