

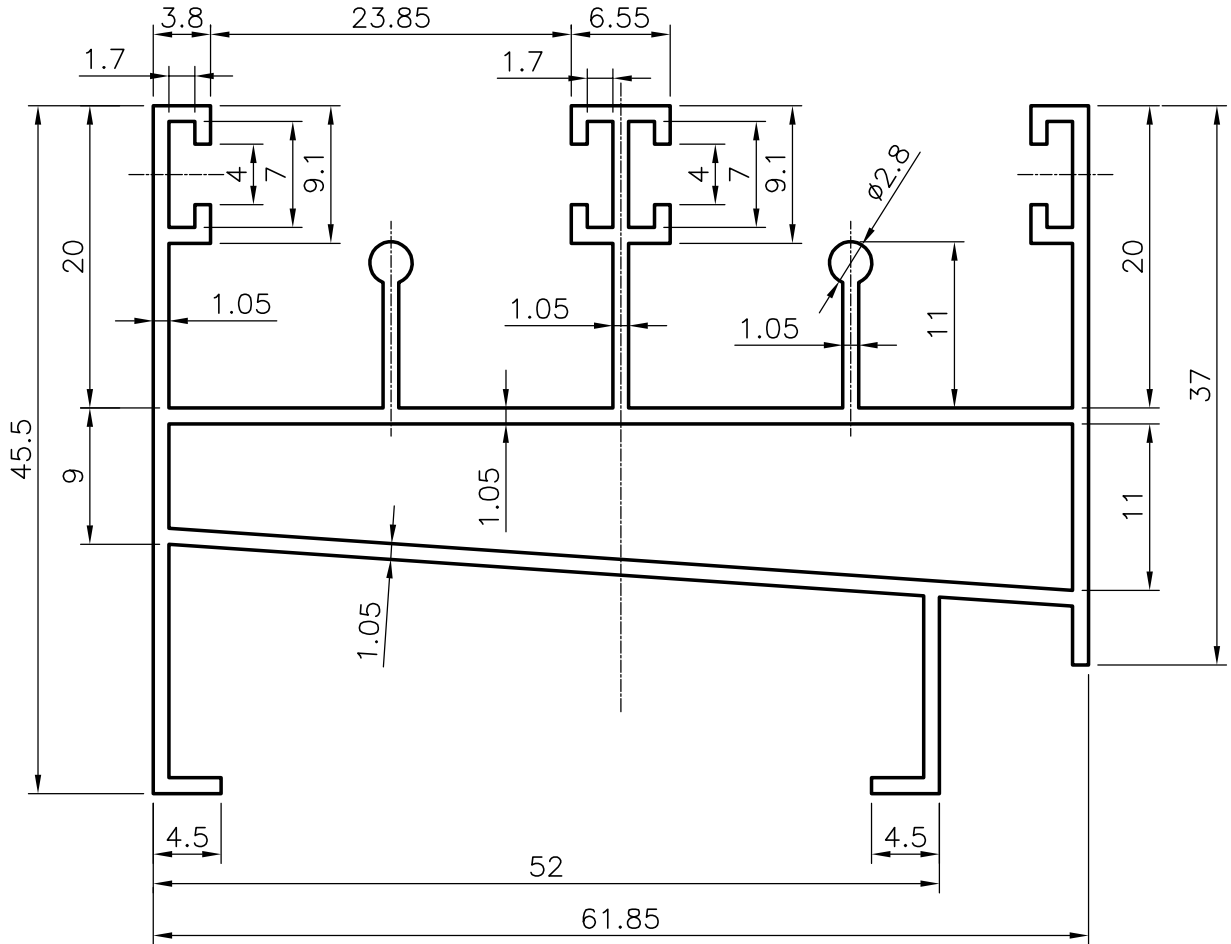

9370
12045
20965

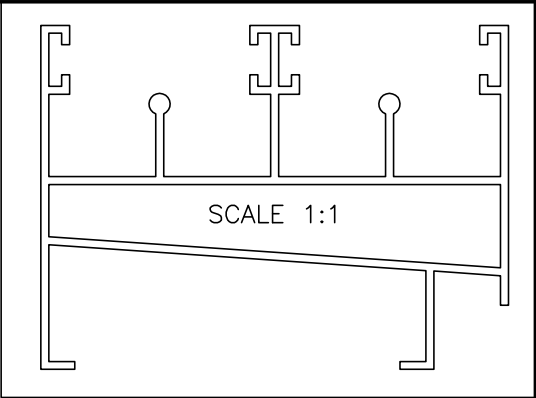

GENERAL WALL THICKNESS = 1.05mm  
 NO. OF PIECES IN 100 kgs = 31 (AVERAGE)

 SYMBOL OF QUALITY AN ISO 9001 COMPANY	<b>JINDAL ALUMINIUM LTD.</b> BANGALORE-560073 (INDIA)	NAME		DATE
		DRAWN	RAGHAVENDRA	23-12-2006
1. ALL DIMENSIONS ARE IN mm. 2. ROUND OFF ALL SHARP CORNERS WITH 0.40 mm. 3. TOLERANCES WILL BE AS PER IS:6477-1983 UNLESS OTHERWISE SPECIFIED		CHECKED		
		APPROVED		
PARTY'S NAME		SCALE		2:1
		AREA mm <sup>2</sup>		326.666
PARTY'S DRAWING No.		PERIMETER mm.		461.157
		WEIGHT kg/m		0.882
ALLOY & TEMPER		DRAWING No.		SECTION No.
		9370		9370
DESCRIPTION		12045		12045
		20965		20965
WINDOW SECTION				