

P-3653

9372

20967

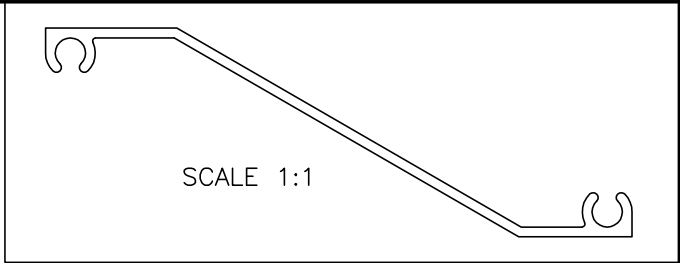

GENERAL WALL THICKNESS = 1.30mm
 F = FULL RADIUS (4 PLACES)

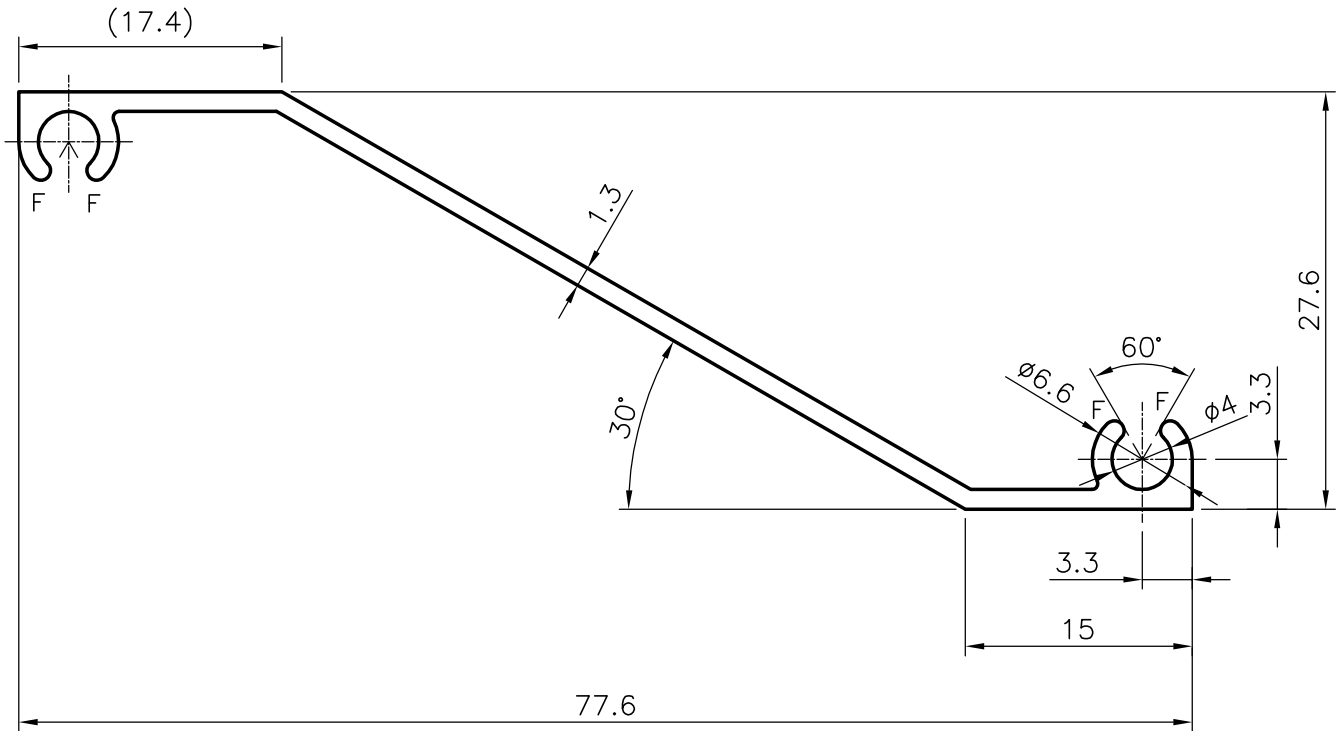

JINDAL ALUMINIUM LTD.
 BANGALORE-560073 (INDIA)

	NAME	DATE
DRAWN	RAGHAVENDRA	23-12-2006
CHECKED		
APPROVED		

1. ALL DIMENSIONS ARE IN mm.
2. ROUND OFF ALL SHARP CORNERS WITH 0.40 mm.
3. TOLERANCES WILL BE AS PER EN12020-2:2001 UNLESS OTHERWISE SPECIFIED

SCALE	2:1
AREA mm ²	136.899
PERIMETER mm.	204.869
WEIGHT kg/m	0.369

PARTY'S NAME	TOM ALUMINIUM L.L.C., U.A.E SHARJAH
PARTY'S DRAWING No.	AS PER DRAWING
ALLOY & TEMPER	6063 T6
DESCRIPTION	WINDOW SECTION

DRAWING No.	SECTION No.
P-3653	-
9372	9372
20967	20967