

S286

9377

12584

20972

SCALE 1:1

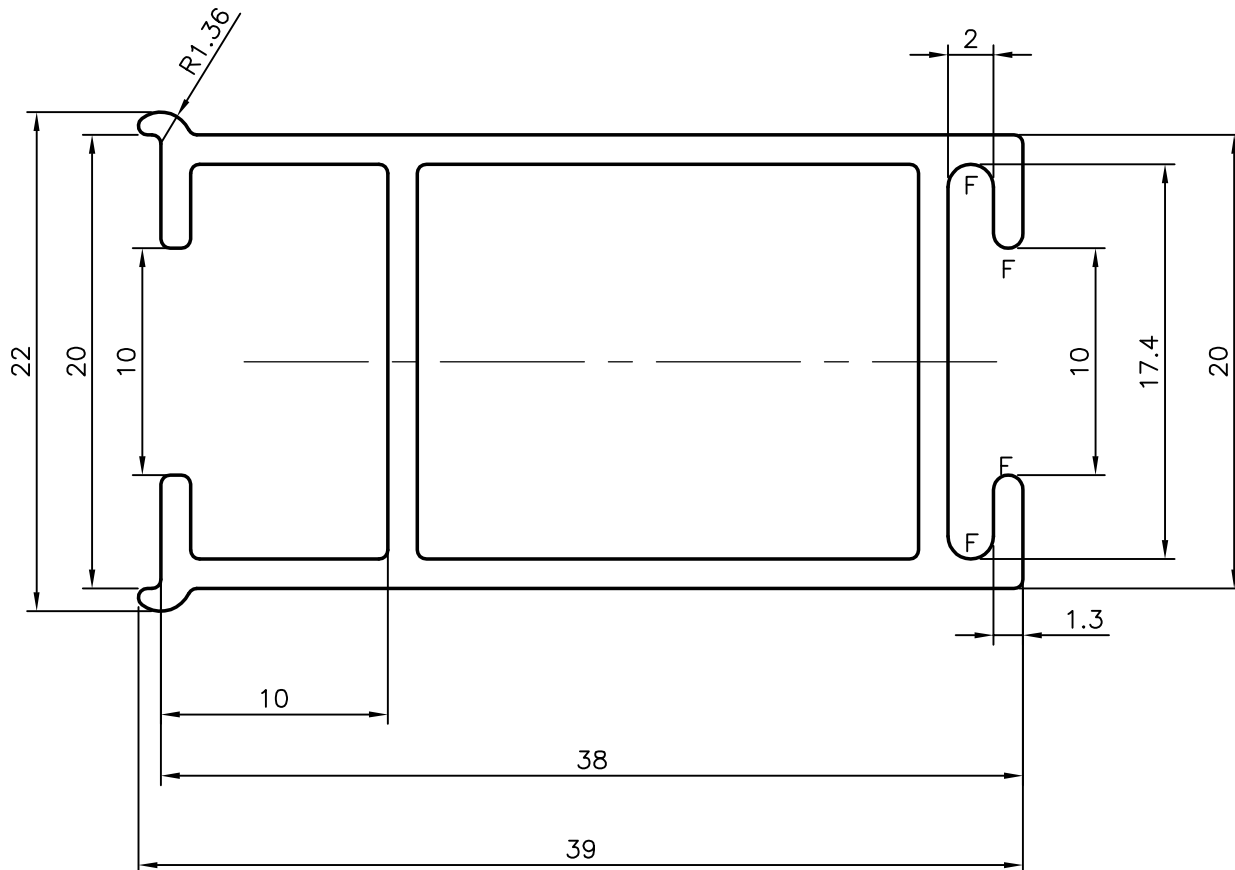

NOTE:-

1. GENERAL WALL THICKNESS = 1.30 mm
2. F= FULL RADIUS (4 PLACES)



SYMBOL OF QUALITY
AN ISO 9001 COMPANY

JINDAL ALUMINIUM LTD.
BANGALORE-560073 (INDIA)

	NAME	DATE
DRAWN	PRASANN.H	27-12-2006
CHECKED		
APPROVED		

1. ALL DIMENSIONS ARE IN mm.
2. ROUND OFF ALL SHARP CORNERS WITH 0.40 mm.
3. TOLERANCES WILL BE AS PER IS:6477-1983 UNLESS OTHERWISE SPECIFIED

SCALE	3:1
AREA mm ²	167.516
PERIMETER mm.	173.091
WEIGHT kg/m	0.451

PARTY'S NAME A.S.B. & SOMS., MADURAI

PARTY'S DRAWING No. AS PER DRAWING

ALLOY & TEMPER HE9 WP

DESCRIPTION HOLLOW PROFILE

DRAWING No.	SECTION No.
S286	S286
9377	9377
12584	12584
20972	20972