

P-4039
9392
20987

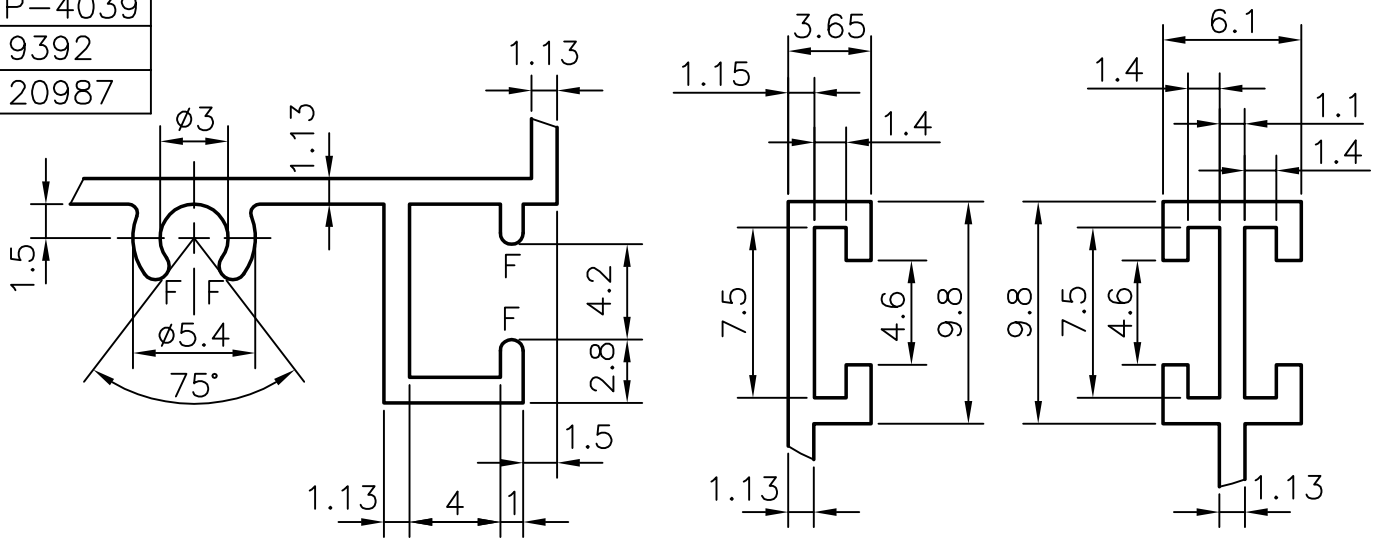

DETAIL 'C'

DETAIL 'A'

DETAIL 'B'

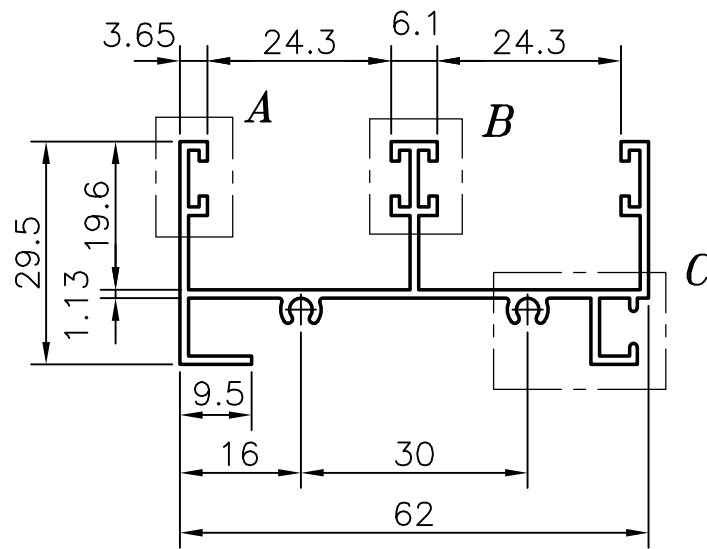

1. GENERAL WALL THICKNESS:- 1.13 mm.
2. F = FULL RADIUS (6)
3. WEIGHT PER 3658 mm. LONG PIECE:- 2.250 kg (AVERAGE)



SYMBOL OF QUALITY
AN ISO 9002 COMPANY

JINDAL ALUMINIUM LTD.
BANGALORE-560073 (INDIA)

	NAME	DATE
DRAWN	R.D.Sharma	15-11-02
CHECKED		
APPROVED		
SCALE	1:1 & 3:1	
AREA mm ²	227.8	
PERIMETER mm.	397.8	
WEIGHT kg/m	0.615	
SECTION No.	20987	
DRAWING No.	20987	

1. ALL DIMENSIONS ARE IN mm. 2. ROUND OFF ALL SHARP CORNERS WITH 0.40 mm. 3. TOLERANCES WILL BE AS PER IS: 3965-1981 UNLESS OTHERWISE SPECIFIED	
PARTY'S NAME	GENERAL CATEGORY, CALCUTTA MARKET
PARTY'S DRAWING No.	LIGHTER OF SECTION NO. 8774
ALLOY & TEMPER	HE9 WP
DESCRIPTION	WINDOW SECTION