

P-4040

9393

20988

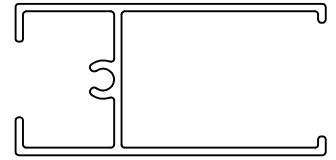

1:1

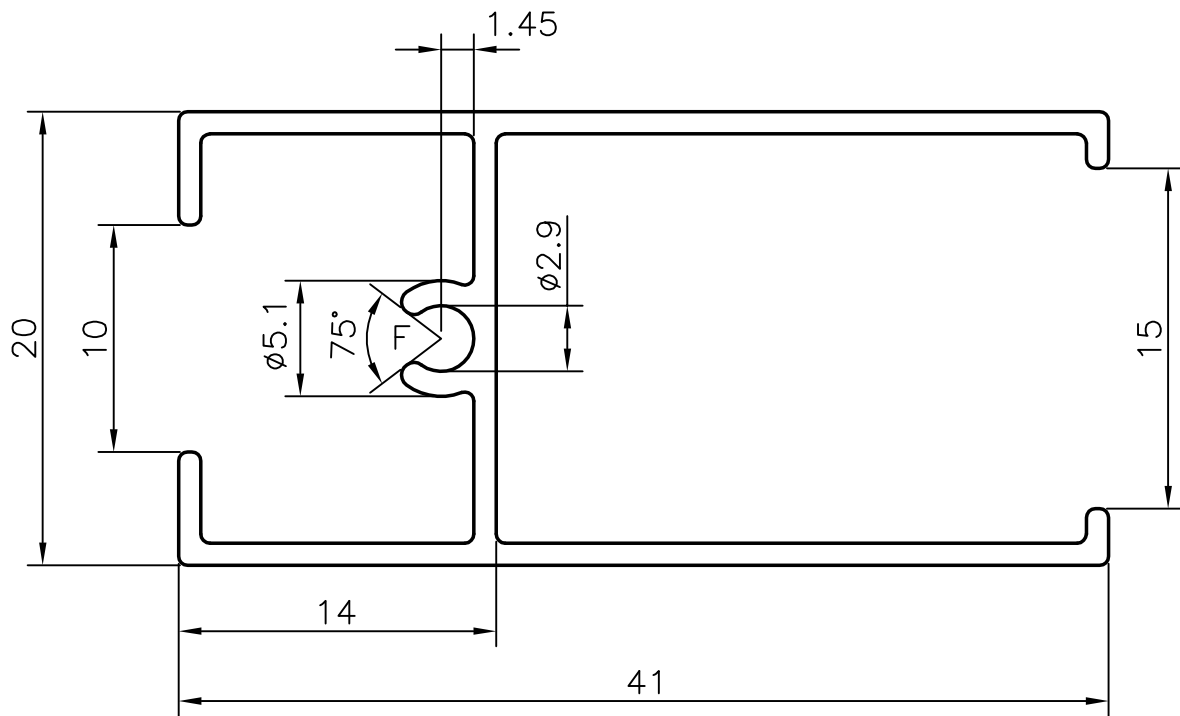

1. GENERAL WALL THICKNESS:- 0.98 mm.
2. F = FULL RADIUS (2)
3. WEIGHT PER 3658 mm. LONG PIECE:- 1.150 kg (AVERAGE)



SYMBOL OF QUALITY
AN ISO 9002 COMPANY

JINDAL ALUMINIUM LTD.
BANGALORE-560073 (INDIA)

	NAME	DATE
DRAWN	R.D.Sharma	15-11-02
CHECKED		
APPROVED		
SCALE	3:1	
AREA mm ²	116.4	
PERIMETER mm.	231.8	
WEIGHT kg/m	0.314	
SECTION No.	20988	
DRAWING No.	20988	

1. ALL DIMENSIONS ARE IN mm.
2. ROUND OFF ALL SHARP CORNERS WITH 0.40 mm.
3. TOLERANCES WILL BE AS PER IS: 3965-1981 UNLESS OTHERWISE SPECIFIED

PARTY'S NAME	GENERAL CATEGORY, CALCUTTA MARKET
PARTY'S DRAWING No.	LIGHTER OF SECTION NO. 8792
ALLOY & TEMPER	HE9 WP
DESCRIPTION	WINDOW SECTION