

**DETAIL AT 'B'**  
(SCALE 4:1)

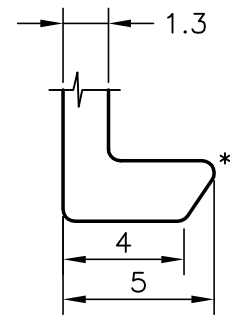

**DETAIL AT 'A'**  
(SCALE 4:1)

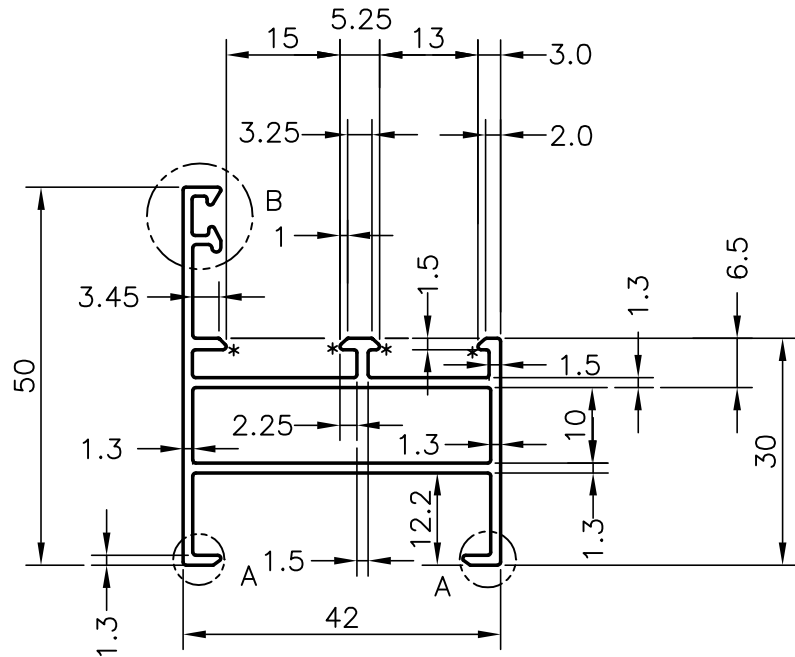

\* = 0.4 RADIUS (8)

20990

9395

X136



SYMBOL OF QUALITY  
AN ISO 9002 COMPANY

**JINDAL ALUMINIUM LTD.**  
**BANGALORE-560073 (INDIA)**

NAME

DATE

DRAWN

RANGASWAMY 18-09-2000

CHECKED

APPROVED

SCALE

1:1

PARTY'S NAME

ALUMILITE ARCHITECTURAL PVT. LTD., MUMBAI

WEIGHT kg/m

0.670

PARTY'S DRAWING No.

AAPL-4200

SECTION No.

20990

ALLOY & TEMPER

HE9 WP

DRAWING No.

DESCRIPTION

ARCHITECTURAL SECTION

20990