

P-4351-2
9408
21003

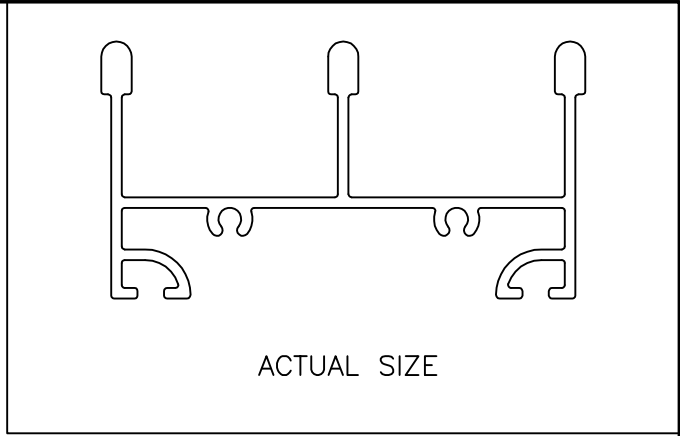

F = FULL RADIOS (AT 4 PLACES)  
 GENERAL WALL THICKNESS 1.40±0.20

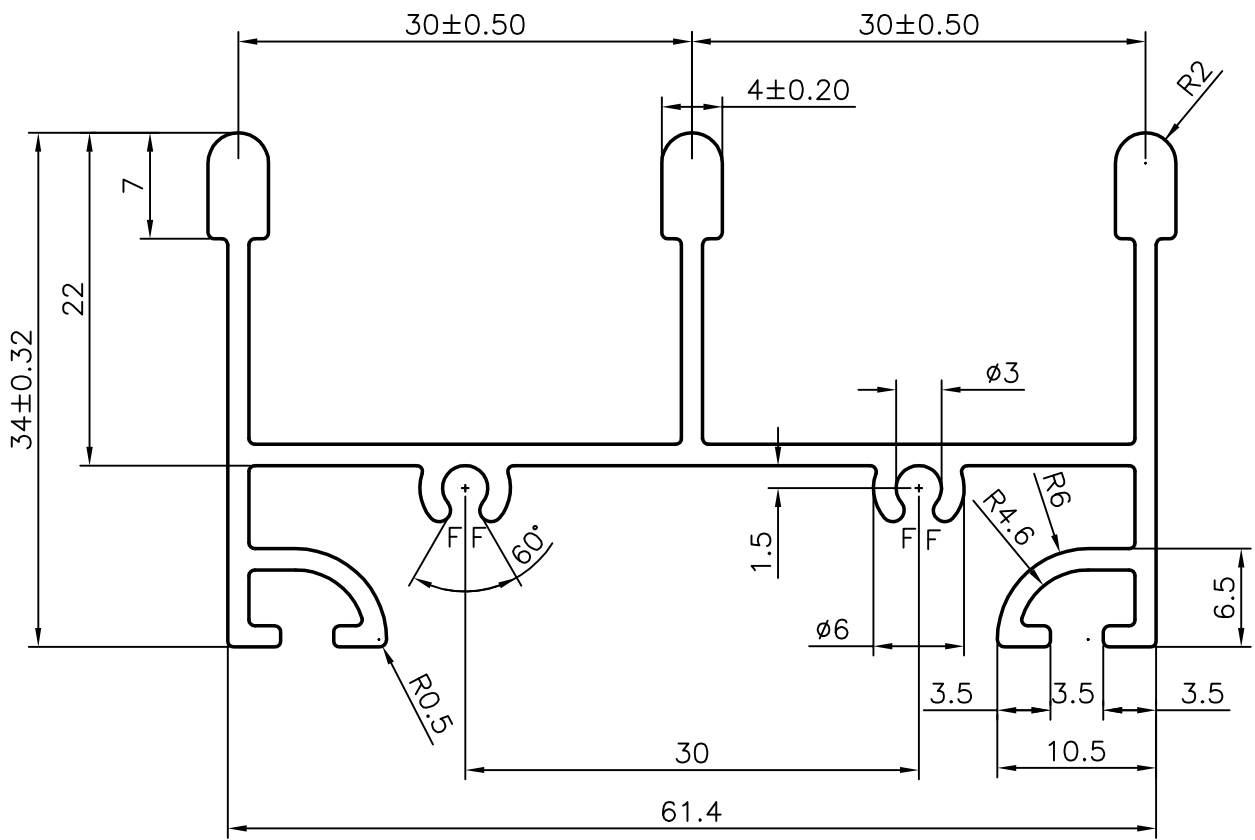

**JINDAL ALUMINIUM LTD.**  
 BANGALORE-560073 (INDIA)

	NAME	DATE
DRAWN	MALINGAPPA	16.08.2003
CHECKED		
APPROVED		
SCALE		2:1
AREA mm <sup>2</sup>		324.3
PERIMETER mm.		390.8
WEIGHT kg/m		0.875
DRAWING No.	SECTION No.	
P-4351-2	-	
9408	9408	
21003	21003	

1. ALL DIMENSIONS ARE IN mm.	
2. ROUND OFF ALL SHARP CORNERS WITH 0.40 mm.	
3. TOLERANCES WILL BE AS PER IS: 3965-1981 UNLESS OTHERWISE SPECIFIED	
PARTY'S NAME	GENERAL CATEGORY, MADRAS MARKET
PARTY'S DRAWING No.	AS PER DRAWING
ALLOY & TEMPER	HE9 WP
DESCRIPTION	WINDOW SECTION