

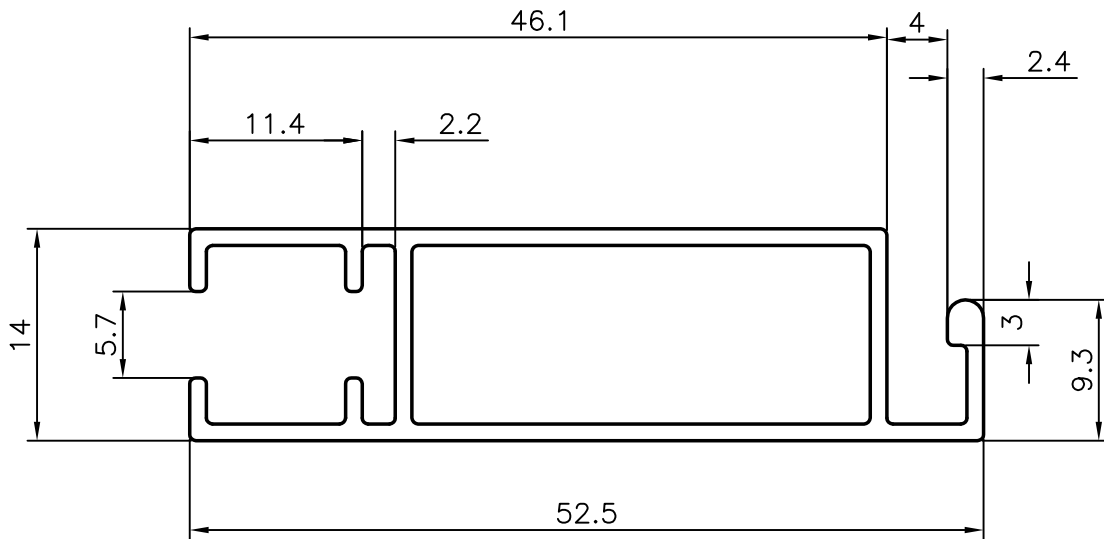

P-4466
9416
21011

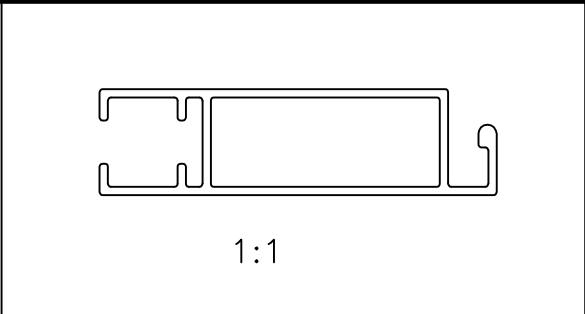

1. GENERAL WALL THICKNESS:- 1.10 mm.

 SYMBOL OF QUALITY AN ISO 9001 COMPANY	JINDAL ALUMINIUM LTD. BANGALORE-560073 (INDIA)	DRAWN	NAME	DATE
		CHECKED	D.K Shaw	08-10-03
1. ALL DIMENSIONS ARE IN mm. 2. ROUND OFF ALL SHARP CORNERS WITH 0.40 mm. 3. TOLERANCES WILL BE AS PER IS: 1474-1987 UNLESS OTHERWISE SPECIFIED		APPROVED		
		SCALE		2:1
PARTY'S NAME TOM ALUMINIUM LLC, SHARJAH		AREA mm ²		160.2
		PERIMETER mm.		198
PARTY'S DRAWING No. LIGHTER OF SECTION NO. 20985		WEIGHT kg/m		0.432
		DRAWING No.	SECTION No.	
ALLOY & TEMPER 6063 T6		P-4466		-
		9416		9416
DESCRIPTION KITCHEN CABINET SECTION		21011		21011