

P-4584

19012

21022

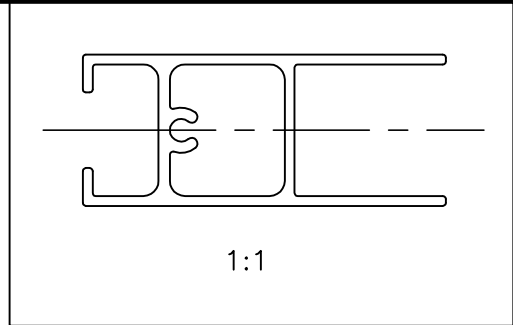
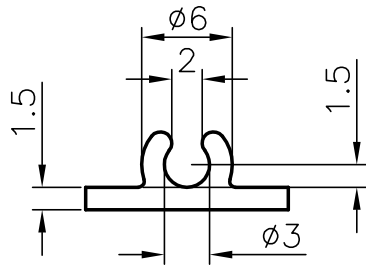

DETAIL A 2:1

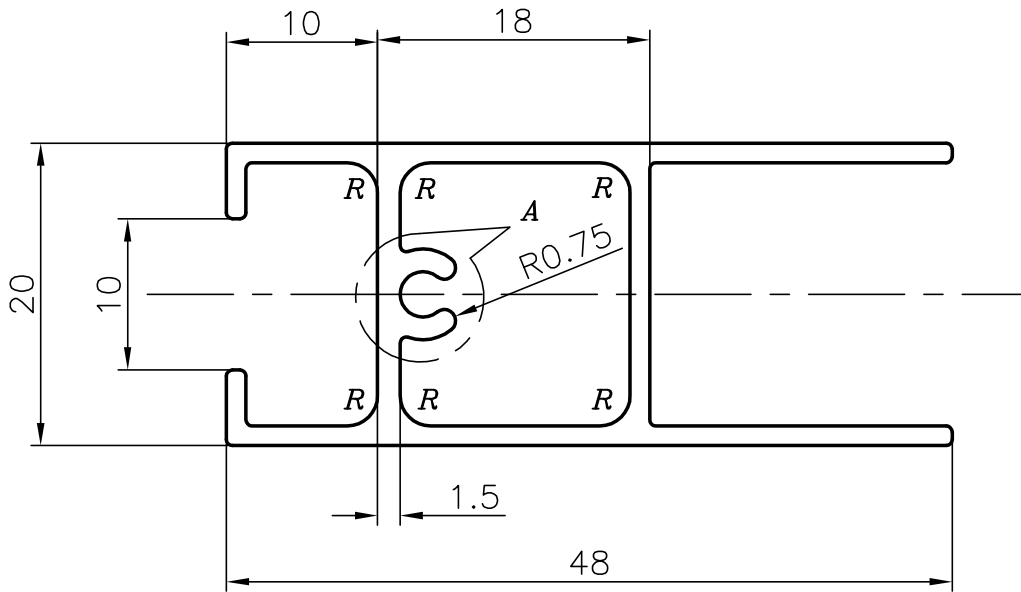

1. GENERAL WALL THICKNESS 1.30 mm.
2. R = 2 mm. RADIUS (6 PLACES)



SYMBOL OF QUALITY
AN ISO 9001 COMPANY

JINDAL ALUMINIUM LTD.
BANGALORE-560073 (INDIA)

	NAME	DATE
DRAWN	D K Shaw	22-11-03
CHECKED		
APPROVED		

1. ALL DIMENSIONS ARE IN mm.
2. ROUND OFF ALL SHARP CORNERS WITH 0.40 mm.
3. TOLERANCES WILL BE AS PER IS: 6477-1983 UNLESS OTHERWISE SPECIFIED

SCALE	2:1
AREA mm ²	199.7
PERIMETER mm.	206.7
WEIGHT kg/m	0.539

PARTY'S NAME	GENERAL CATEGORY, MADRAS MARKET	DRAWING No.	SECTION No.
PARTY'S DRAWING No.	AS PER DRAWING	P-4584	-
ALLOY & TEMPER	HE9 WP	19012	19012
DESCRIPTION	WINDOW SECTION	21022	21022