

19020

21030

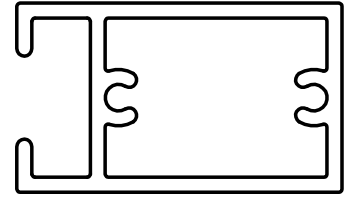

SCALE 1:1

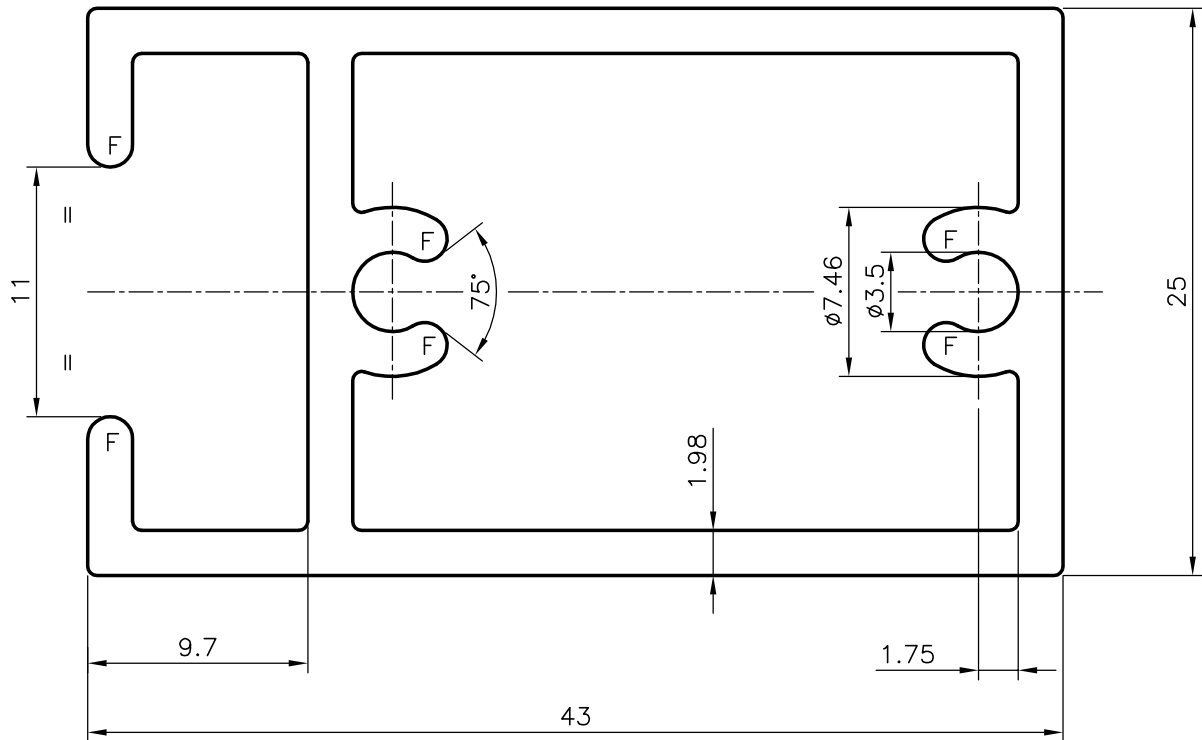

GENERAL WALL THICKNESS = 1.98mm

F = FULL RADIUS (6 PLACES)

3658mm LONG PIECES IN 100kgs = 33 (AVERAGE)



SYMBOL OF QUALITY  
AN ISO 9002 COMPANY

**JINDAL ALUMINIUM LTD.**  
BANGALORE-560073 (INDIA)

	NAME	DATE
DRAWN	RAGHAVENDRA	12-01-2004
CHECKED		
APPROVED		

1. ALL DIMENSIONS ARE IN mm.
2. ROUND OFF ALL SHARP CORNERS WITH 0.40 mm.
3. TOLERANCES WILL BE AS PER IS:6477-1983 UNLESS OTHERWISE SPECIFIED

SCALE	3:1
AREA mm <sup>2</sup>	306.613
PERIMETER mm.	172.407
WEIGHT kg/m	0.828

PARTY'S NAME	GENERAL CATEGORY	DRAWING No.	SECTION No.
PARTY'S DRAWING No.	HEAVIER SECTION OF 8660	19020	19020
ALLOY & TEMPER	HE9 WP	21030	21030
DESCRIPTION	WINDOW SECTION		