

P-3319
S703
19028
21038

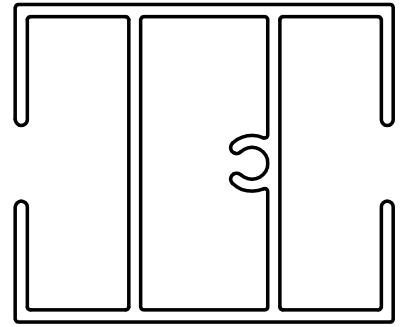

SCALE 1:1

GENERAL WALL THICKNESS :-1.6mm
F = FULL RADII(6 PLACES)

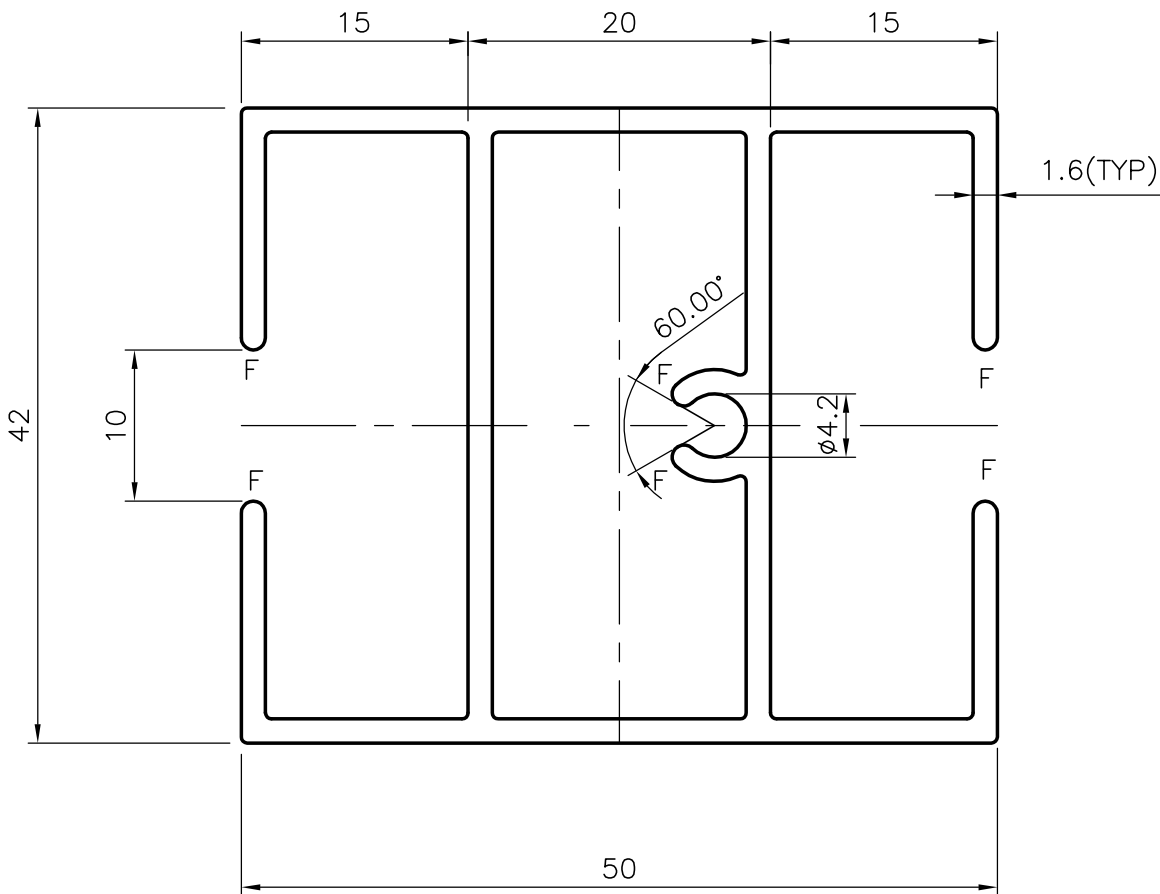

SYMBOL OF QUALITY
AN ISO 9002 COMPANY

JINDAL ALUMINIUM LTD.
BANGALORE-560073 (INDIA)

	NAME	DATE
DRAWN	RAGHAVENDRA	11-06-2001
CHECKED		
APPROVED		
SCALE	2:1 , 1:1	
WEIGHT kg/m	1.059	
SECTION No.	21038	
DRAWING No.	21038	

1. ALL DIMENSIONS ARE IN mm.
2. ROUND OFF ALL SHARP CORNERS WITH 0.40 mm.
3. TOLERANCES WILL BE AS PER IS 6477-1983 UNLESS OTHERWISE SPECIFIED

PARTY'S NAME	NINANS TRADING COMPANY . ADOOR
PARTY'S DRAWING No.	AS PER DRAWING(NT83)
ALLOY & TEMPER	HE9 WP
DESCRIPTION	WINDOW SECTION