

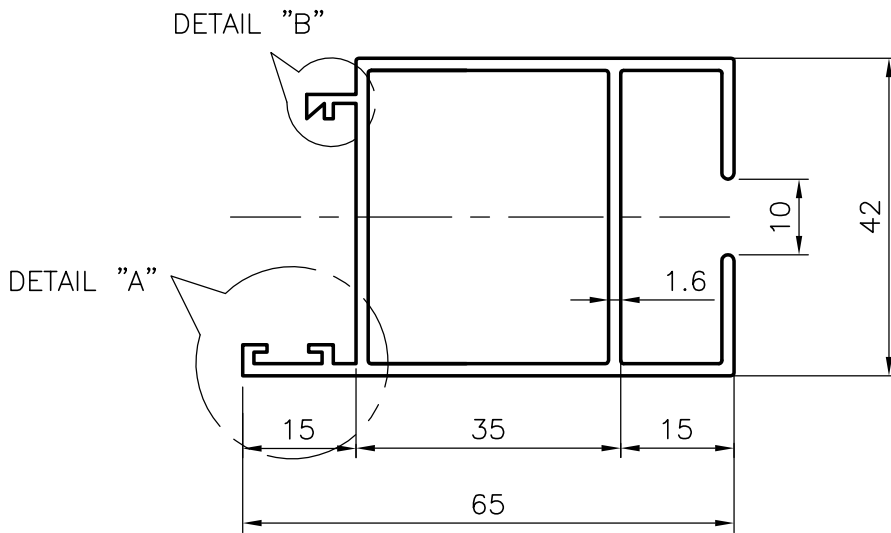

P-3320
S704
19029
21039

DETAL "A"
SCALE 4:1

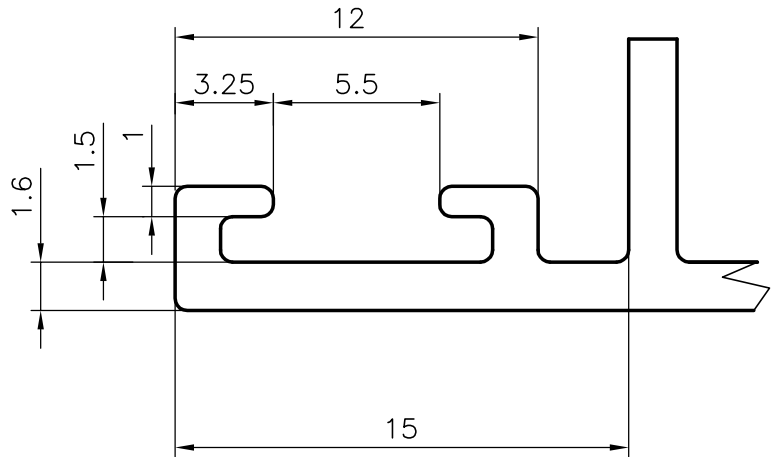
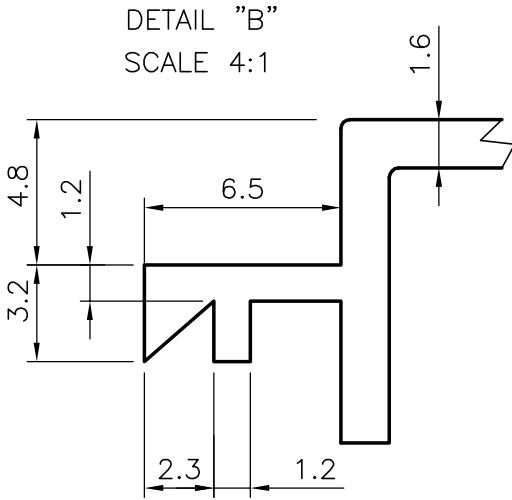

GENERAL WALL THICKNESS :-1.6mm

F = FULL RADII(2PLACES)

 SYMBOL OF QUALITY AN ISO 9002 COMPANY	JINDAL ALUMINIUM LTD. BANGALORE-560073 (INDIA)		NAME	DATE
		DRAWN	RAGHAVENDRA	11-06-2001
1. ALL DIMENSIONS ARE IN mm. 2. ROUND OFF ALL SHARP CORNERS WITH 0.40 mm. 3. TOLERANCES WILL BE AS PER IS 6477-1983 UNLESS OTHERWISE SPECIFIED		CHECKED		
		APPROVED		
		SCALE	4:1 , 1:1	
PARTY'S NAME	NINANS TRADING COMPANY ADOOR	WEIGHT kg/m	1.018	
PARTY'S DRAWING No.	AS PER DRAWING (NT83)	SECTION No.	21039	
ALLOY & TEMPER	HE9 WP	DRAWING No.		
DESCRIPTION	WINDOW SECTION	21039		