

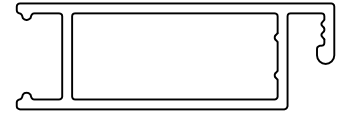

P-4695
19031
21041

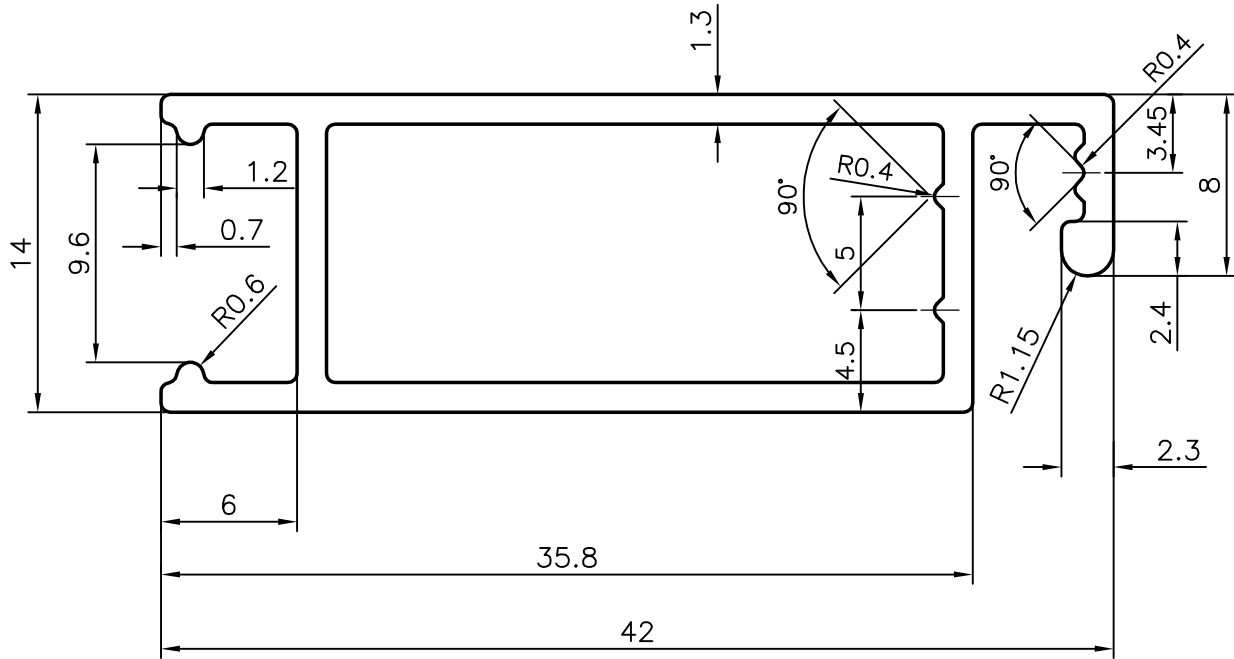

SCALE 1:1



GENERAL WALL THICKNESS = 1.30mm

 SYMBOL OF QUALITY AN ISO 9002 COMPANY	<b>JINDAL ALUMINIUM LTD.</b> BANGALORE-560073 (INDIA)	NAME		DATE
		DRAWN	RAGHAVENDRA	19-03-2004
1. ALL DIMENSIONS ARE IN mm. 2. ROUND OFF ALL SHARP CORNERS WITH 0.40 mm. 3. TOLERANCES WILL BE AS PER BS:1474-1987 UNLESS OTHERWISE SPECIFIED		CHECKED		
		APPROVED		
PARTY'S NAME SYDNEY ALUMINIUM & GLASS DOHA		SCALE		3:1
		AREA mm <sup>2</sup>		144.518
PARTY'S DRAWING No. AS PER SAMPLE		PERIMETER mm.		138.825
		WEIGHT kg/m		0.390
ALLOY & TEMPER 6063 T6		DRAWING No.		SECTION No.
		P-4695		-
DESCRIPTION FLY MESH SECTION		19031		19031
		21041		21041