

P-4704

19032

21042

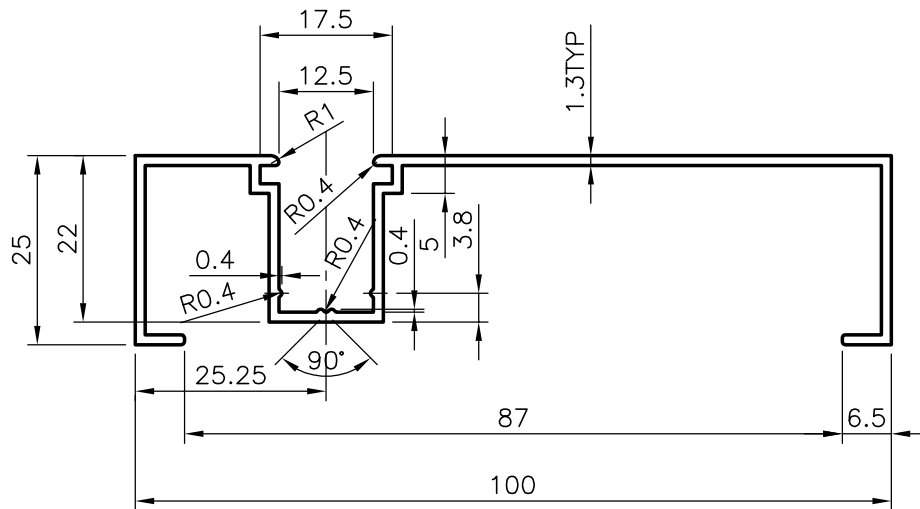

GENERAL WALL THICKNESS = 1.30mm



SYMBOL OF QUALITY  
AN ISO 9002 COMPANY

**JINDAL ALUMINIUM LTD.**  
BANGALORE-560073 (INDIA)

	NAME	DATE
DRAWN	RAGHAVENDRA	19-03-2004
CHECKED		
APPROVED		

1. ALL DIMENSIONS ARE IN mm.
2. ROUND OFF ALL SHARP CORNERS WITH 0.40 mm.
3. TOLERANCES WILL BE AS PER BS:1474-1987 UNLESS OTHERWISE SPECIFIED

SCALE	1:1
AREA mm <sup>2</sup>	265.99
PERIMETER mm.	410.281
WEIGHT kg/m	0.718

PARTY'S NAME SYDNEY ALUMINIUM & GLASS DOHA

PARTY'S DRAWING No. AS PER SAMPLE

ALLOY & TEMPER 6063 T6

DESCRIPTION WINDOW SECTION

DRAWING No.	SECTION No.
P-4704	-
19032	19032
21042	21042