

P-4748-3

19037

21047

GENERAL WALL THICKNESS = 1.40mm
 F = FULL RADIUS (4 PLACES)
 R = 1.5 RADIUS (9 PLACES)

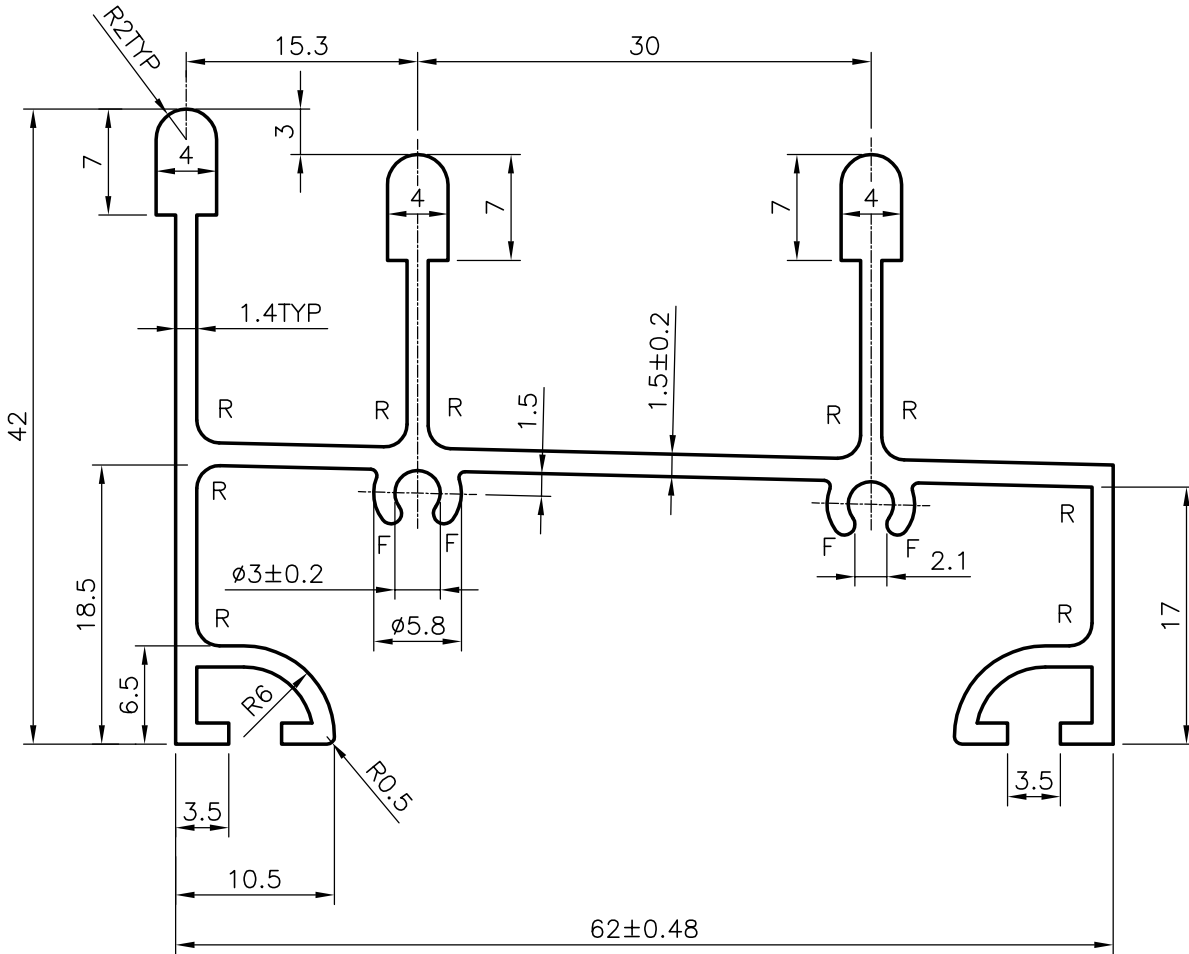
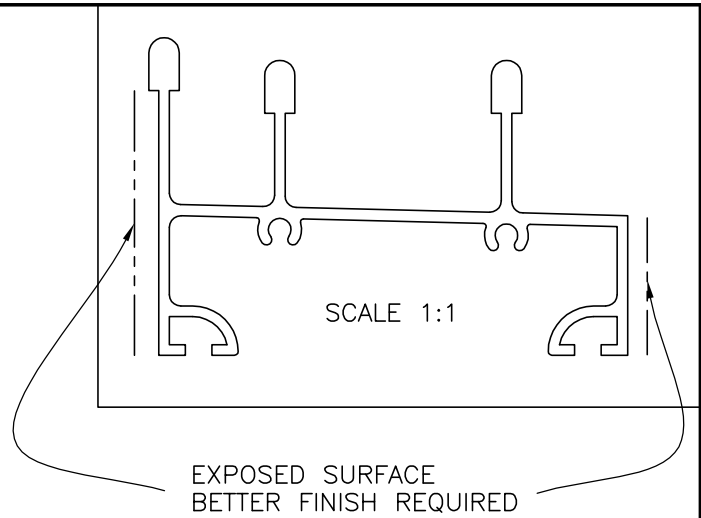

JINDAL ALUMINIUM LTD.
 BANGALORE-560073 (INDIA)

	NAME	DATE
DRAWN	RAGHAVENDRA	16-03-2004
CHECKED		
APPROVED		

1. ALL DIMENSIONS ARE IN mm.
2. ROUND OFF ALL SHARP CORNERS WITH 0.40 mm.
3. TOLERANCES WILL BE AS PER IS:3965-1981 UNLESS OTHERWISE SPECIFIED

SCALE	2:1
AREA mm ²	348.116
PERIMETER mm.	414.478
WEIGHT kg/m	0.94

PARTY'S NAME	GENERAL CATEGORY, CHENNAI MARKET
PARTY'S DRAWING No.	AS PER SKETCH
ALLOY & TEMPER	HE9 WP
DESCRIPTION	WINDOW SECTION

DRAWING No.	SECTION No.
P-4748-3	-
19037	19037
21047	21047